



## **C30XR**

3-WAY STEREO  
ELECTRONIC CROSSOVER NETWORK

**OWNEN'S MANUAL**

# INTRODUCTION

## FEATURES:

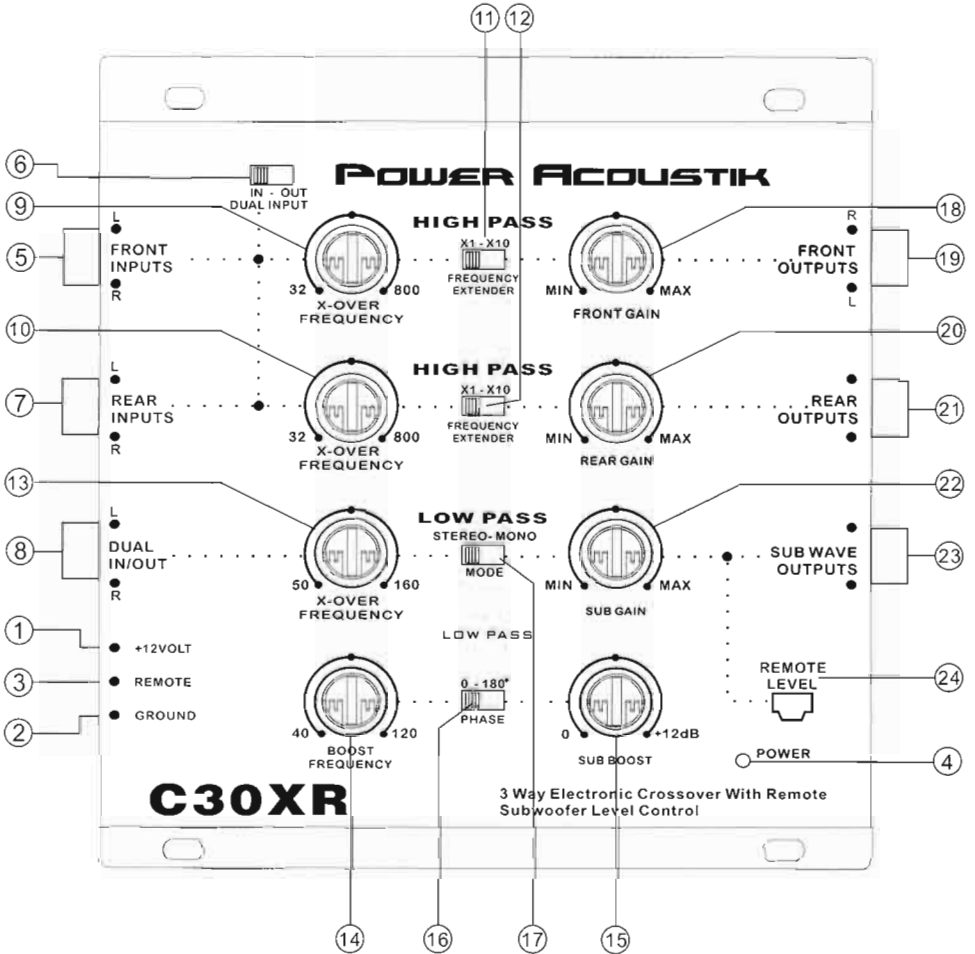

# FUNCTIONS

## 1. POWER INPUT TERMINAL (12V)

To be connected to the positive terminal of your vehicle battery or other constant +12V source.

## 2. GROUND INPUT TERMINAL

To be wired to the vehicle's chassis ground.

## 3. REMOTE TURN-ON INPUT TERMINAL (REMOTE)

To be connected to the remote control wire or antenna lead of the source unit for remote ON/OFF.

## 4. POWER INDICATOR

This indicator lights up when the internal switching power supply is activated and the unit is operational.

## 5. LEFT/RIGHT FRONT CHANNEL SIGNAL INPUTS

To be connected to the front channel output of the source unit.

## 6. DUAL INPUT SWITCH

**"IN"** : When the parallel input is at the IN position, the input signals coming in through the front channel signal inputs are split and directed to the front and rear channels simultaneously. (This feature is to be engaged where the source unit has no separate front ,rear or subwoofer channel outputs.)

**"OUT"**: If the source unit has independent front and rear channel outputs, disengage the parallel input by sliding the switch to the OUT position.

## 7. LEFT/RIGHT REAR CHANNEL SIGNAL INPUTS

To be connected to the rear channel outputs of the source unit. BUT MAKE SURE THAT THE DUAL INPUT SWITCH IS AT THE OUT POSITION.

## 8. LEFT/RIGHT DUAL IN/OUT TERMINALS

**As Input Terminal:** To be connected to the subwoofer output of the source unit.

**As Output Terminal:** To be connected to the front channel input terminal of another electronic crossover in a multi-crossover system.

## 9. FRONT CHANNEL HIGH-PASS FREQUENCY SELECTOR

For selection of front channel high-pass crossover frequency between 32Hz and 800Hz (or 320Hz and 8K Hz when its frequency multiplier is at x10 position).

## 10. REAR CHANNEL HIGH-PASS FREQUENCY SELECTOR

For selection of rear channel high-pass crossover frequency between 32Hz and 800Hz.

## 11. FRONT CHANNEL HIGH-PASS FREQUENCY EXTENDER

Positioning the switch at the x10 position changes, the range of selectable crossover frequency for the front channel high-pass from 32Hz to 800Hz, 320Hz - 8KHz.

# FUNCTIONS

## 12. REAR CHANNEL HIGH-PASS FREQUENCY EXTENDER

Positioning the switch at the x10 position changes, the range of selectable crossover frequency for the front channel high-pass from 32Hz to 800Hz, 320Hz - 8KHz.

## 13. SUBWOOFER FREQUENCY SELECTOR

For selection of the low-pass crossover frequency for the subwoofer channel between 50Hz and 160Hz.

## 14. BASS-BOOST FREQUENCY CONTROL

For setting the frequency (from 40Hz to 120Hz) at which the BASS-BOOST circuitry generates frequency boost to equalize the woofer enclosure.

## 15. BASS-BOOST LEVEL CONTROL

For selection of the boost level (from 0 to +12 dB).

## 16. PHASE INVERTER

Positioning the switch to the 180° position shifts the subwoofer output signals 180 degrees out-of-phase relative to the front and rear output signals.

## 17. SUBWOOFER STEREO/MONO SWITCH

For selection of stereo or mono mode subwoofer output.

## 18. FRONT CHANNEL OUTPUT GAIN CONTROL

For adjusting the front channel output signal level.

## 19. LEFT/RIGHT FRONT CHANNEL OUTPUT TERMINALS

To be connected to the front channel amplifier left/right inputs.

## 20. REAR CHANNEL OUTPUT GAIN CONTROL

For adjusting the rear channel output signal level.

## 21. LEFT/RIGHT REAR CHANNEL OUTPUT TERMINALS

To be connected to the rear channel amplifier left/right inputs.

## 22. SUBWOOFER OUTPUT GAIN CONTROL

For adjusting the subwoofer channel output signal level.

## 23. LEFT/RIGHT SUBWOOFER OUTPUT TERMINALS

To be connected to the subwoofer channel amplifier left/right inputs.

## 24. SUBWOOFER OUTPUT LEVEL REMOTE CONTROL TERMINAL

To be connected to the remote control for exclusive maneuver of the subwoofer output level, and the subwoofer output level control on the unit ( 21 above) is by-passed.

# ELECTRICAL & AUDIO CONNECTIONS

(A) 2-Channel Two-Way System  
(tweeter + full range)

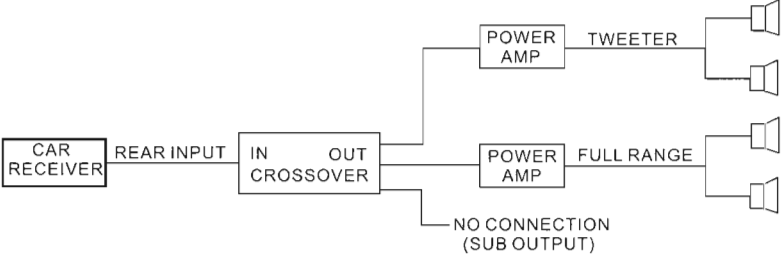

(B) 2-Channel Two-Way System  
(tweeter + woofer)

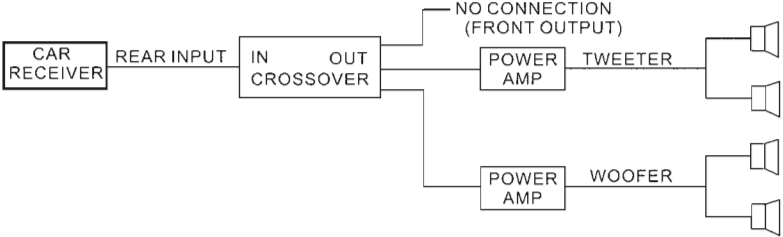

(C) 4-Channel TRI-AMP System

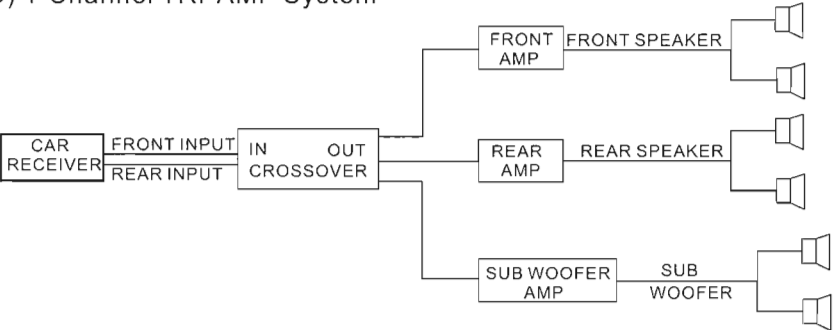

# ELECTRICAL & AUDIO CONNECTIONS

(D) 2-Channel multiple purpose system

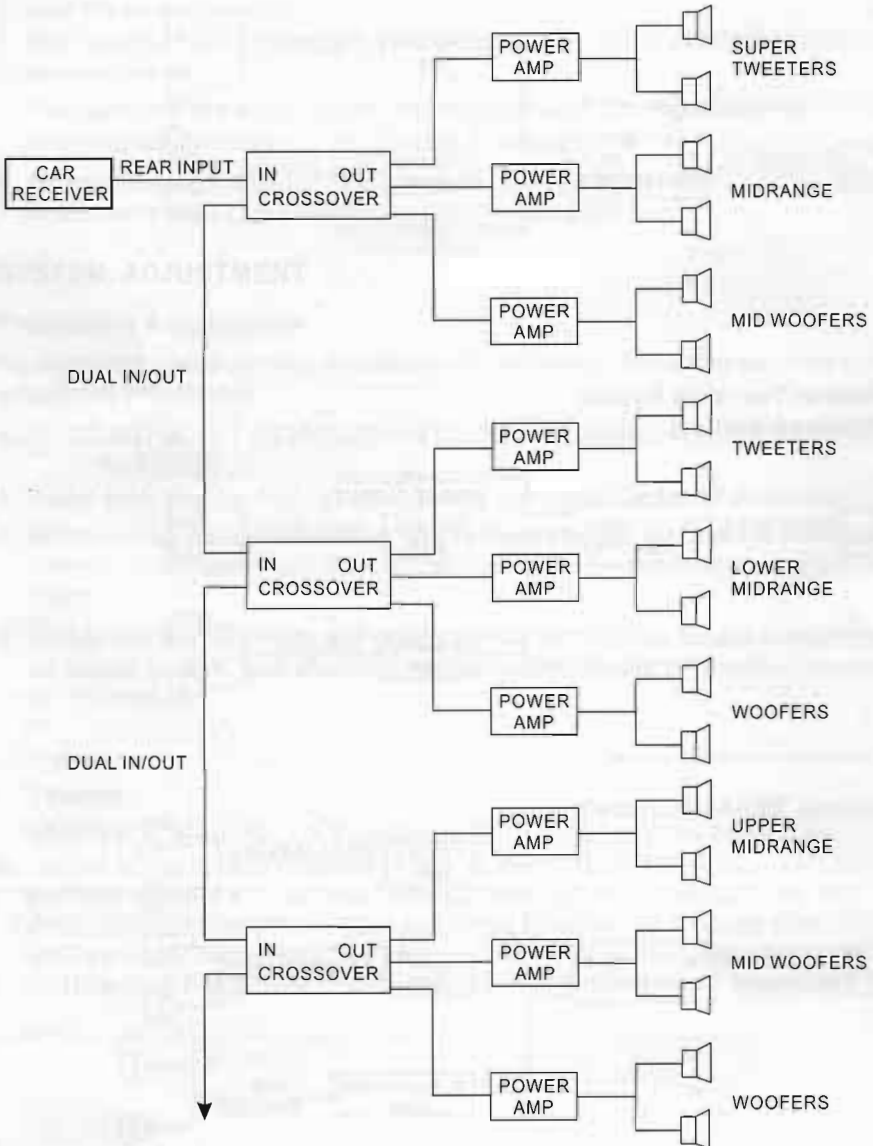

## ELECTRICAL & AUDIO CONNECTIONS

### Precautions

1. To prevent short circuits, be sure to disconnect the negative battery ground lead before wiring the system up.
2. When you finish the installation, be sure to make one more check to be sure everything is done correctly.
3. Reinstall all car parts that were removed.
4. Reconnect the negative battery ground lead.

### Primary Wiring Descriptions

ELECTRICAL	PRIME CONNECTION	DESCRIPTION
12V	BATTERY+	Connect to the positive battery terminal (constant + 12V source)
GROUND	GROUND-	Connect to the vehicle's chassis ground (check for good ground)
REMOTE	REMOTE B+	Connect to the remote control wire (or the electrical antenna) of the car radio/cassette deck
CROSSOVER INPUT/OUTPUT	PRIME CONNECTION	DESCRIPTION
FRONT INPUT	RADIO/TAPE PLAYER TO CROSSOVER MODULE	Connect from pre-amp output of radio/tape player(or CD) into
REAR INPUT	RADIO/TAPE PLAYER TO CROSSOVER MODULE	Connect from pre-amp output of radio/tape player(or CD) into
DUAL IN/OUT	CROSSOVER MODULE TO ANOTHER CROSSOVER MODULE	Connect from CROSSOVER to the input or DUAL the In/Out of another
FRONT OUTPUT	CROSSOVER MODULE TO FRONT AMPLIFIER	Connect from front output of CROSSOVER module to front amplifier input
REAR OUTPUT	CROSSOVER MODULE TO REAR AMPLIFIER	Connect from rear output of CROSSOVER module to front amplifier input
SUB-WOOFER OUTPUT	CROSSOVER MODULE TO SUB-WOOFER AMPLIFIER	Connect from sub-woofer output of CROSSOVER to sub-woofer amplifier input.

## **NOISE CHECK & SYSTEM ADJUSTMENT**

### **NOISE CHECK**

Check the entire audio system for noise before permanently securing the CROSSOVER mounting

1. Start the engine.
2. Turn the audio system on.
3. Rev the engine and vary the VOLUME of the audio system to determine if there is any unwanted noise.

If so, turn both the audio system and the engine off. Do not secure the CROSSOVER mounting screws. Refer to the "Trouble Shooting Guide" at this manual.

4. If the audio system does not have any noise, securely tighten the CROSSOVER mounting screws and double check the wiring cables for safe placement.

### **SYSTEM ADJUSTMENT**

#### **Preliminary Adjustments**

Pre-setting the system provides a necessary starting point for fine-tuning the entire audio system to maximum performance.

**NOTE: DO NOT MOUNT CROSSOVER UNTIL THE FOLLOWING PROCEDURES HAVE BEEN COMPLETED.**

1. Preset each amplifier input gain adjustment at the amplifier to half of maximum.
2. Before turning the audio system on, preset-adjust the front, rear and sub-woofer output level controls, as well as the front channel high-pass and sub-woofer channel low-pass crossover points.
3. Slowly turn the volume up and listen carefully for: Obvious trouble in sound (distortion, no sound, no hiss, total silence). Turn the system off refer to "Trouble Shooting Guide" at this manual.

#### **Caution**

**DO NOT ROUTE AUDIO CABLES AND POWER CABLES TOGETHER! THIS CAN CAUSE ENGINE NOISE IN YOUR AUDIO SYSTEM. ALWAYS DISCONNECT THE SYSTEM FROM THE BATTERY BEFORE ATTEMPTING TO MAKE OR ALTER ANY CONNECTIONS, THIS PRODUCT IS DESIRED FOR USE IN ANY 12VOLTS NEGATIVE GROUND ELECTRICAL SYSTEM ONLY, INSTALLING THIS PRODUCT IN ANY POSITIVE GROUND ELECTRICAL SYSTEM COULD SERIOUSLY DAMAGE THE AUDIO SYSTEM.**



## TROUBLE SHOOTING GUIDE

PROBLEM	POSSIBLE CAUSE
1. There is an audible distortion at a low volume level.	Output levels NOT set correctly.
2. A whining sound can be heard through the speakers when the audio system is at low volume with the engine running. The whining noise remains unchanged or seems to disappear when the volume level is increased.	Check the red power wire, it must be connected directly to the battery. Check the system's ground point, it must make good contact with chassis ground (bare metal), The radio and the CROSSOVER must be grounded at the same reference point.
3. There is a "motor boating" type of sound when the engine is running and the audio system volume is set at a reasonably high level.	Check the red power wire, it must be connected directly to the battery. Check the system's ground point, it must make good contact with chassis ground (bare metal).

# INSTALLATION

## INSTALLATION

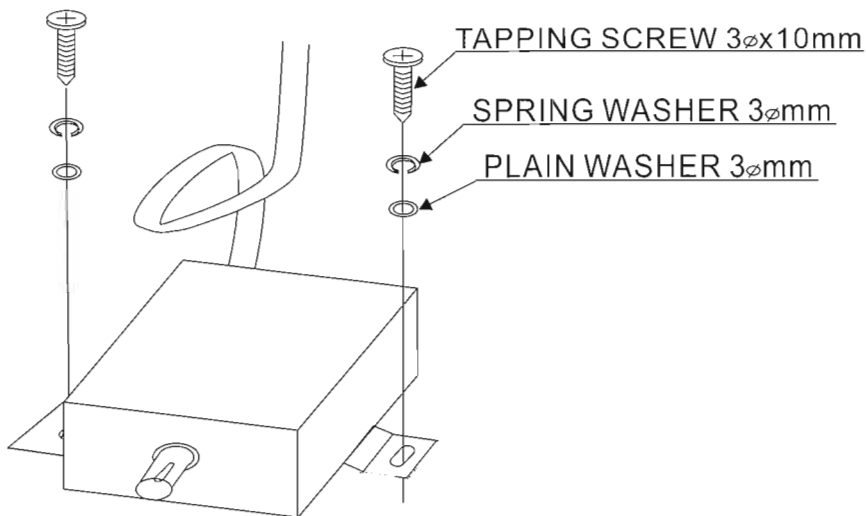
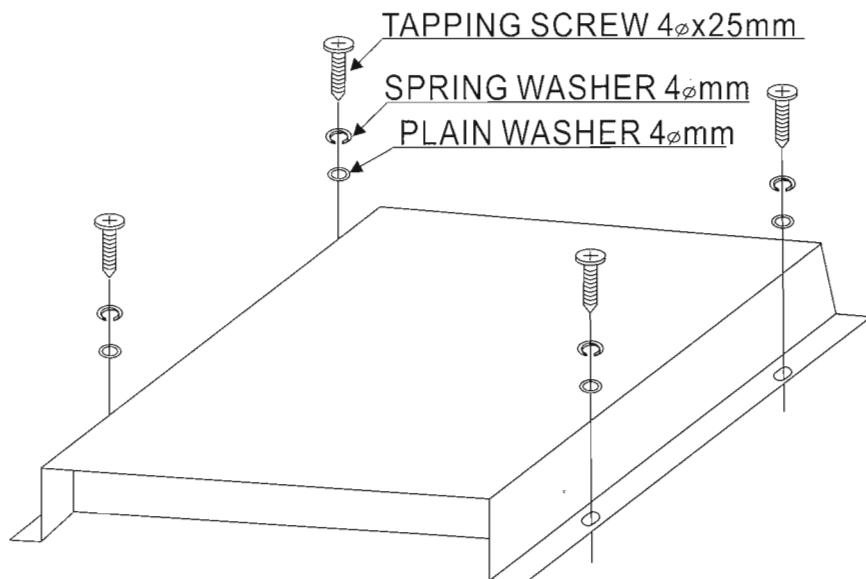

# SPECIFICATIONS

## SPECIFICATIONS

Power source:	14.4 volts DC negative ground
Input current:	0.5 amp max
Distortion:	0.01% THD at 1V output level
Frequency response:	10Hz- 30K Hz $\pm$ 3dB
S/N ratio (A weighted):	> 95 dB
Separation:	60 dB
Crossover frequencies (continuously variable):	
Front High-pass:	(x1): 32 -800 Hz (X10): 320 -8K Hz
Rear High-pass:	(x1): 32 -800 Hz (X10): 320 -8K Hz
Subwoofer:	50 -160 Hz
Crossover slope rate:	12 dB per octave 2nd Order Butter worth
Subwoofer boost:	Single octave 0dB to 12dB (variable) at 40 to 120Hz (variable)
Input impedance:	> 10K Ohms
Output impedance:	< 1 K Ohms
Output gain:	+3 dB
Output voltage level:	5 volts max
Dimensions:	6-7/8" W x 7-1/2" L x 1-3/8" H(175mm x 191mm x 35 mm)

FEATURES AND SPECIFICATIONS SUBJECT TO CHANGE AND / OR IMPROVEMENT WITHOUT NOTICE