

## Precautions

Before you drill or cut any holes, investigate your car's layout very carefully. Take care when you work near the gas tank, fuel lines, hydraulic lines and electrical wiring.

Do not operate the amplifier when it is not mounted. Attach all audio system components securely within the automobile to prevent damage, especially in case of an accident.

Do not mount this amplifier so that the wire connections are unprotected or in a pinched condition, or likely to be damaged by nearby objects.

Before making or breaking power connections in your system, disconnect the vehicle battery. Confirm that your head unit or other equipment is turned off while connecting the input jacks and speaker terminals.

If you need to replace the power fuse, replace it only with a fuse identical to that supplied with the system. Using a fuse of different type or rating may result in damage to your system which isn't covered by the manufacturer's warranty.

# **POWER ACOUSTIK**

## **CLASS D MONOBLOCK AMPLIFIER**

**DEMON SERIES**

**D1-2000D/D1-3000D**

**D1-4000D/D1-6000D**

**Owner's Manual and  
Installation Guide**

# SPECIFICATIONS

MODELS	D1-2000D	D1-3000D	D1-4000D	D1-6000D
Power MAX (1 Ohms)	2000 x 1	3000 x 1	4000 x 1	6000 x 1
Power MAX (2 Ohms)	1000 x 1	1500 x 1	2000 x 1	3000 x 1
Power RMS (4 Ohms)	500 x 1	750 x 1	1000 x 1	1500 x 1
S/N Ratio	103dB	103dB	103dB	103dB
Low Pass Crossover (Variable)	50Hz-150Hz	50Hz-150Hz	50Hz-150Hz	50Hz-150Hz
Bass Boost (Variable)	0 - 18dB	0 - 18dB	0 - 18dB	0 - 18dB
Inputs	Low Level and Speaker Level Inputs.....			
Remote Subwoofer Control	Yes	Yes	Yes	Yes
Frequency Response	50Hz-150Hz	50Hz-150Hz	50Hz-150Hz	50Hz-150Hz
THD (at RMS Output)	0.01%	0.01%	0.01%	0.01%
Channel Separation	90dB	90dB	90dB	90dB
Damping Factor	180+	180+	180+	180+
Fuse Values	25A x 2	30A x 3	35A x 4	250A x 1
Dimensions ( 11.8" x 2.6" x L )	L = 11.6	L = 13.7	L = 17.76	L = 22.64

# FEATURES

## CLASS D MONOBLOCK AMPLIFIER

D1-2000D,D1-3000D,D1-4000D,D1-6000D

- One Ohm Stable Monoblock Amplifier
- MOSFET Power Supply
- PWM (Pulse Width Modulation) System
- Nickel-plated RCA Low Level Inputs
- Nickel-plated Speaker and Power Terminals
- Input Sensitivity Selector
- Variable Subsonic Filter (10Hz-40Hz)
- Variable Low Pass Filter (50Hz-150Hz)
- Bass Boost: 0 to 18dB
- 0/180° Phase Selector
- Soft Turn-On Circuit
- Remote Turn-On/Turn-Off Circuit
- Remote Subwoofer Lever Control

# Built-in Crossover

All **POWER ACOUSTIK** DEMON amplifiers feature built-in electronic crossovers. The DEMON amplifiers also feature continuously-variable low pass crossovers and fixed high pass crossovers.

All **POWER ACOUSTIK** DEMON amplifiers have been designed to utilize 100% MOSFET power supplies, ensuring extremely rapid switching response for plenty of clean power.

# Protection Circuitry

The amplifier protection circuitry will disable the amplifier if the inputs are overloaded, short-circuited or extremely high temperature conditions are detected. When the protection mode is in operation, the LED indicator on the front panel will be illuminated, indicating the amplifier has gone into a self-preservation mode.

If you observe that the protection LED is lit, please check the system carefully to determine what has caused the protection circuit to engage. The amplifier can be reset by turning the remote power off and then on again. If the amplifier shuts down due to a thermal overload condition, please allow it to cool down before powering up. If the amplifier shuts down because of an input overload or short circuit, be sure to repair these conditions before attempting to power up the amplifier again.

# 2 Ohm Operation(in stereo mode)

Your DEMON SERIES amplifier was designed to operate effectively at loads down 2 Ohms. This means that you can install four 8 Ohm speakers per channel when using parallel wiring. Increasing the number of woofers per channel at low frequencies (up to 100Hz) produces an acoustic coupling effect. This acoustic coupling increases your power output by 3 dB per speaker.

When operating at 2 Ohms, the amplifiers will increase their output power by approximately 50%. The current draw will also increase by about the same amount, so be sure you have enough current to run the amplifiers into a 2 Ohm load. If you lack adequate current, your music reproduction will be distorted.

Please note: The gain control of any car audio amplifier should not be mistaken for a volume control. It is a sophisticated device, designed to match the output level of your audio source unit to the input level of the amplifier. Do not adjust this input level to maximum unless your input level requires it. Ignoring these instructions will result in an input overload to the amplifier, and excessive audio distortion. It can also cause the protection circuit to engage.

## Electrical Wiring

All **DEMON SERIES** power amplifiers are equipped with easy top access screw terminals. These terminals are nickel-plated in order to ensure excellent electrical contact and to resist corrosion.

When making electrical connections to the amplifier, please observe the following:

- Use at least 8 gauge or heavier wire for power and ground connections.
- Wire the amplifier directly to the car battery. Make sure there is circuit protection (Such as a fuse) on the positive power lead, within 18 inches of the battery.
- For the ground connection, use the shortest possible wire to a good chassis ground point.
- Wire the Remote connection to the remote turn-on lead of your equalizer or head unit. In some cases this may be the power antenna lead of the head unit.

## Remote Subwoofer Level Control

All **DEMON SERIES** power amplifiers are equipped with a dashboard mount remote subwoofer level control. Run the supplied dashboard remote control from the front panel of your amplifier. By turning the level knob clockwise, you will increase the output of low frequencies.

## Fuses

Fuses protect both the amplifier and the electrical system of your vehicle from faulty conditions. If you must replace the fuse in your **DEMON** amplifier, use a fuse of exactly the same type and rating. A different type or rating may result in damage or cause a fire.

## Mounting the Amplifier

Mark the location for the mounting screw holes by positioning the amplifier where you wish to install it and use a scribe (or one of the mounting screws) inserted in each mounting hole to mark the mounting surface. If the mounting surface is carpeted, measure the hole centers and mark with a felt tip pen.

Drill pilot holes in the mounting surface for the mounting screws and insert the mounting screws into these holes. Tighten them securely.

**Note:** Before beginning your installation, be sure to take note of any wires, lines or other devices in your vehicle which may be located behind any mounting surface.

## Low Level Input Connections:

Low-level(RCA)input wiring is preferred for best audio performance. Always use a high-quality RCA cable for best audio performance.

Class D Monoblock Amplifiers:

### D1-2000D, D1-3000D

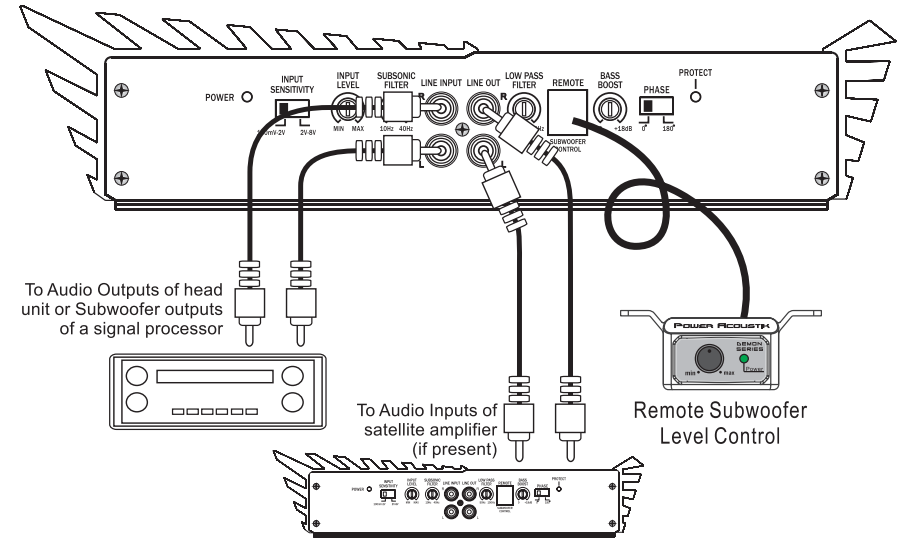

### D1-4000D, D1-6000D

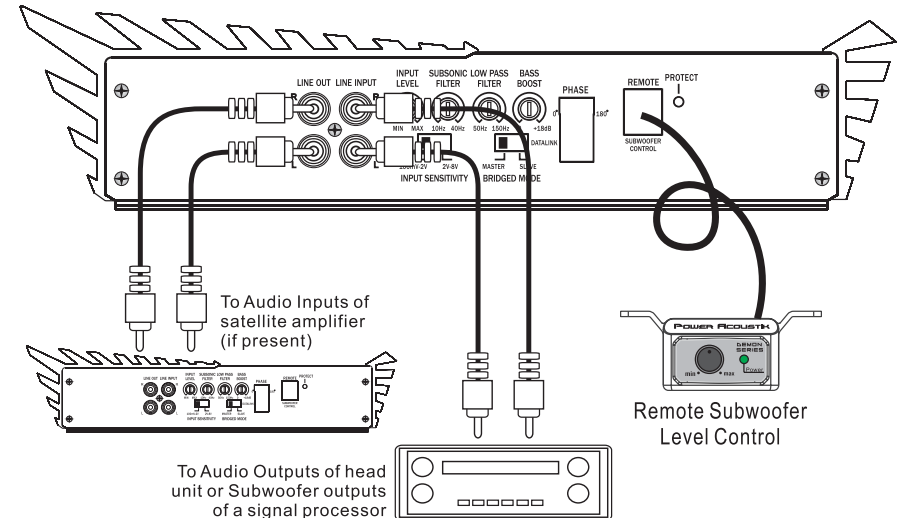

## Power and Speaker Connections

Class D Monoblock Amplifiers:  
**D1-2000D, D1-3000D**

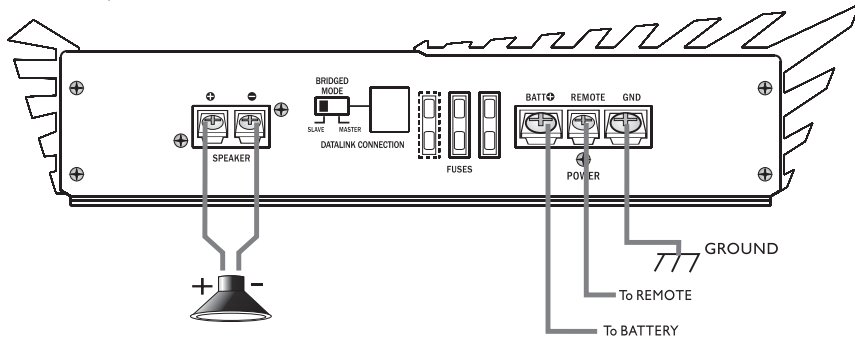

**D1-4000D**

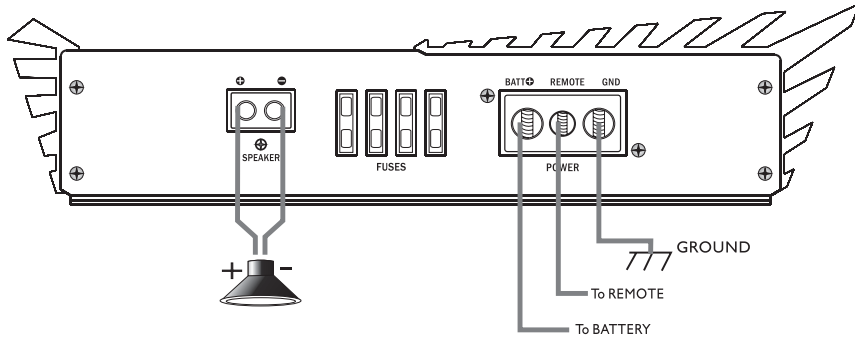

**D1-6000D**

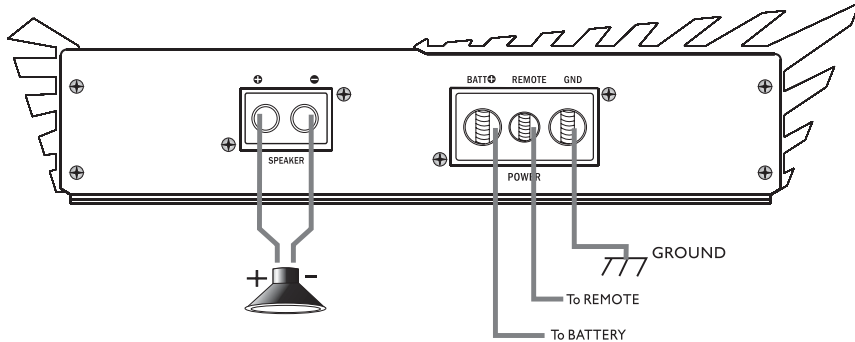

## Bridging Two D1-2000D or D1-3000D Amplifiers

INPUT CONNECTIONS

(SEE NEXT PAGE FOR POWER, SPEAKER AND DATALINK CONNECTIONS)

MASTER  
 AMPLIFIER  
 Front panel

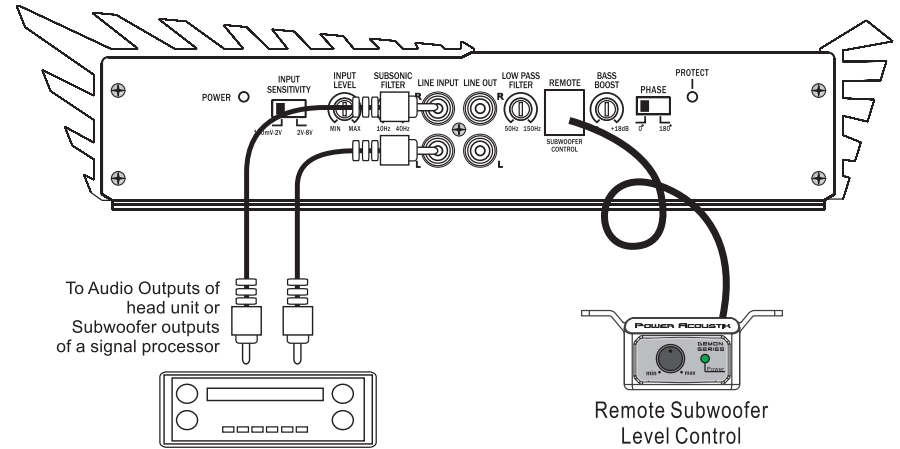

SLAVE  
 AMPLIFIER  
 Front panel

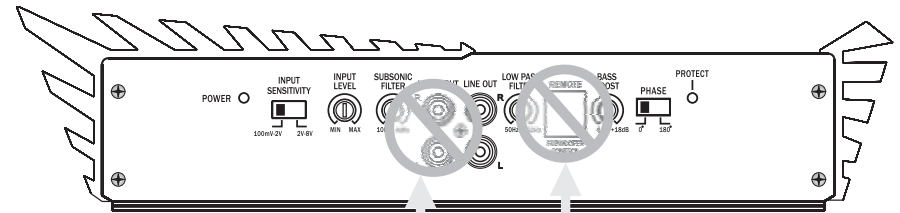

PLEASE NOTE:  
 In this MASTER AMP/SLAVE AMP configuration, the Slave amp receives its audio signal from the Master Amp. Therefore, DO NOT USE THE INPUTS ON THE SLAVE AMP!

PLEASE NOTE:  
 In this MASTER AMP/SLAVE AMP configuration, the Slave amp receives its audio signal from the Master Amp. Therefore, DO NOT USE THE SUBWOOFER LEVER CONTROL ON THE SLAVE AMP!

## Bridging Two D1-2000D or D1-3000D Amplifiers

### POWER AND SPEAKER CONNECTIONS

(SEE PREVIOUS PAGE FOR INPUT CONNECTIONS)

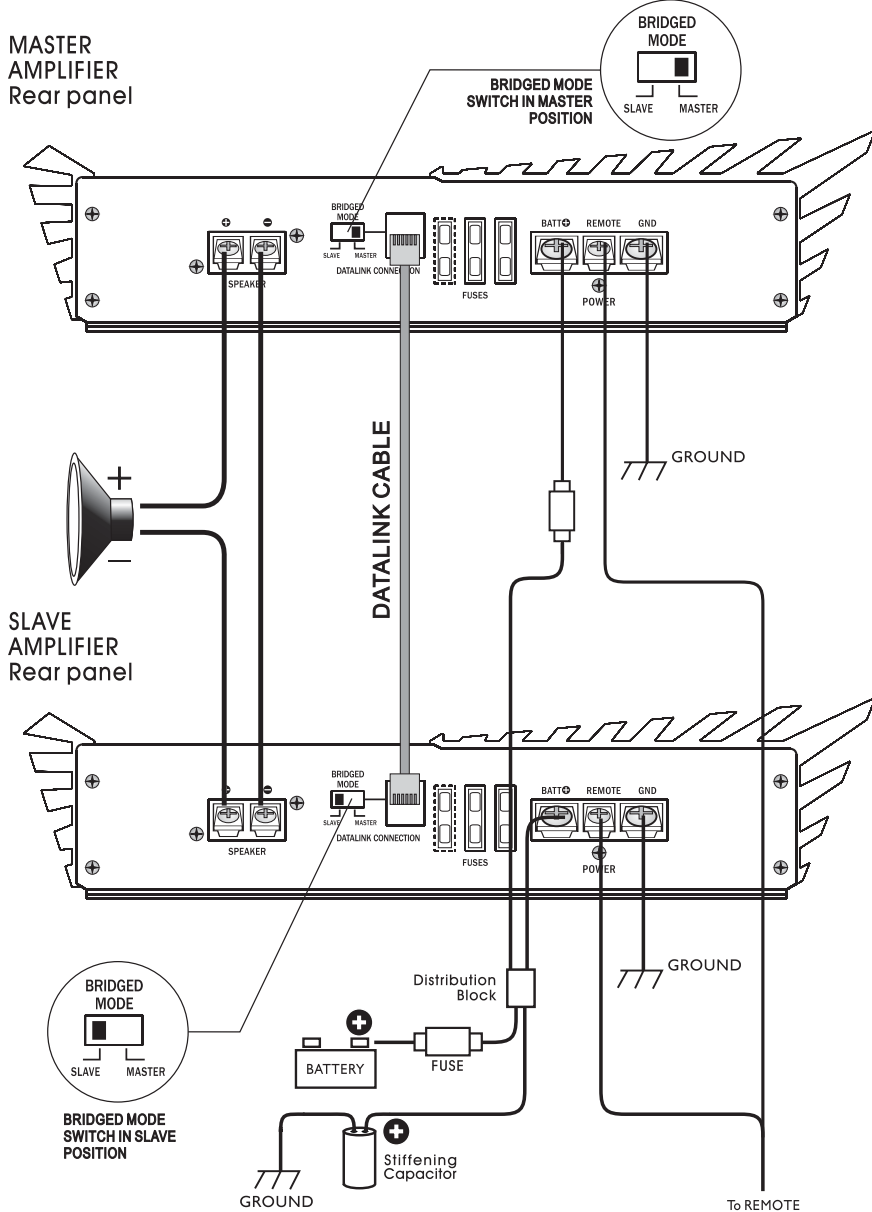

## Bridging Two D1-4000D or D1-6000D Amplifiers

### INPUT CONNECTIONS

(SEE NEXT PAGE FOR POWER, SPEAKER AND DATALINK CONNECTIONS)

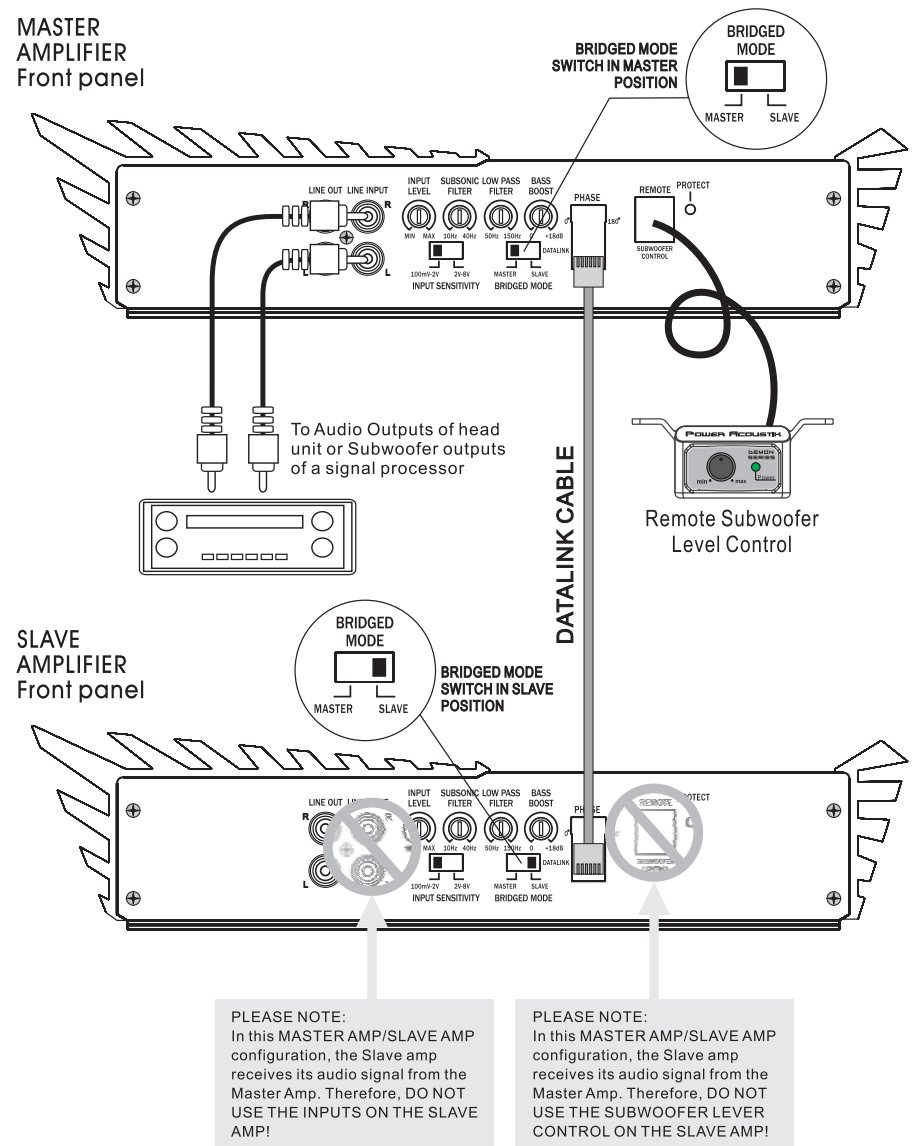

**PLEASE NOTE:**  
In this MASTER AMP/SLAVE AMP configuration, the Slave amp receives its audio signal from the Master Amp. Therefore, DO NOT USE THE INPUTS ON THE SLAVE AMP!

**PLEASE NOTE:**  
In this MASTER AMP/SLAVE AMP configuration, the Slave amp receives its audio signal from the Master Amp. Therefore, DO NOT USE THE SUBWOOFER LEVER CONTROL ON THE SLAVE AMP!

**Bridging Two D1-4000D Amplifiers**  
**POWER AND SPEAKER CONNECTIONS**  
*(SEE PREVIOUS PAGE FOR INPUT CONNECTIONS)*

MASTER  
 AMPLIFIER  
 Rear panel

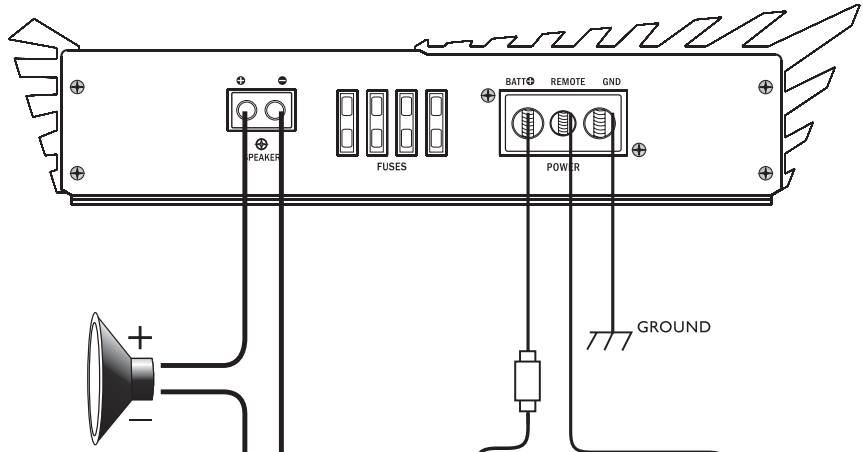

SLAVE  
 AMPLIFIER  
 Rear panel

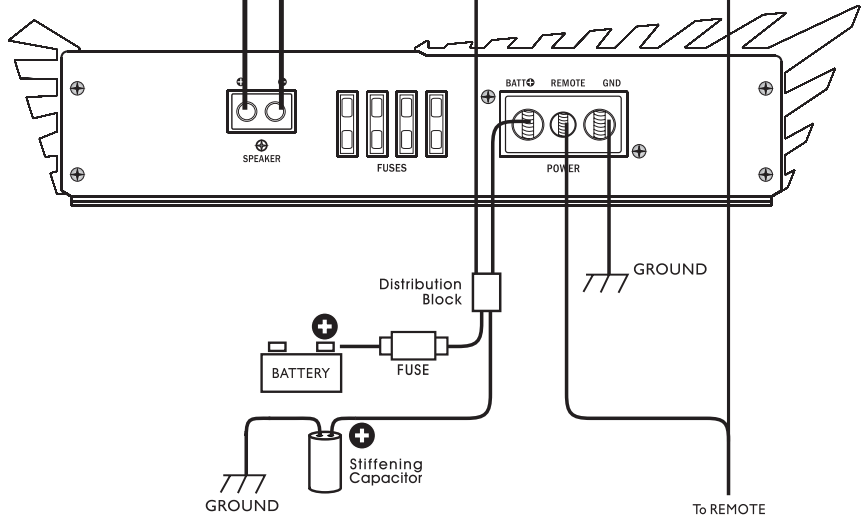

**Bridging Two D1-6000D Amplifiers**  
**POWER AND SPEAKER CONNECTIONS**  
*(SEE PREVIOUS PAGE FOR INPUT CONNECTIONS)*

MASTER  
 AMPLIFIER  
 Rear panel

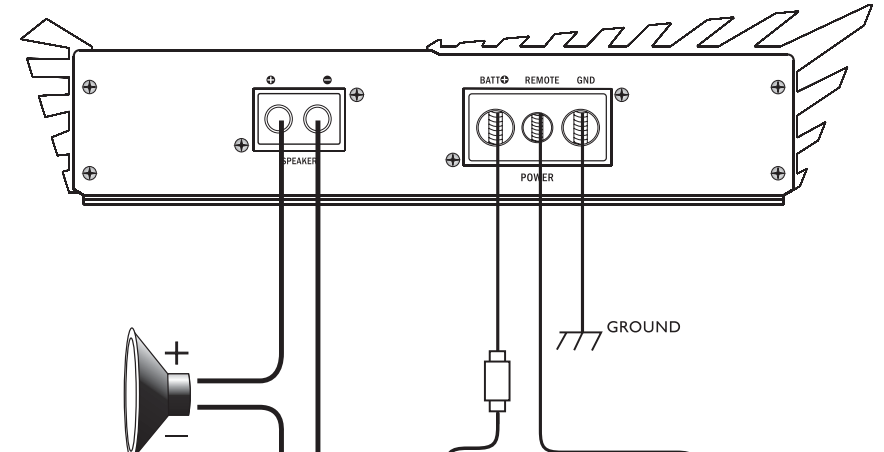

SLAVE  
 AMPLIFIER  
 Rear panel

