



POWER ACOUSTIK®

www.poweracoustik.com

GOTHIC
SERIES

Owner's Manual

GT2-400 • GT2-600 • GT2-900 • GT2-1300 • GT2-1800

GT4-900 • GT4-1200 • GT4-1800 • GT4-2600

GT5-2500

GT1-1000 • GT1-1600

GT1-2400D • GT1-3500D • GT1-4500D • GT1-6000D

INTRODUCTION

Thank you for purchasing **POWER ACOUSTIK** amplifier.

It is a state - of - the - art product carefully designed and manufactured for vehicle use and has been thoroughly tested to ensure consistent reliable performance.

POWER ACOUSTIK Amplifiers provide high-performance sound reinforcement for your mobile audio equipment. Its versatility enables compatibility with Frequency Dividing Crossover and other audio processors in a customized system. The Multimode bridging capabilities allow flexibility in hosting several different speaker configurations.

To achieve optimum performance & longevity, it is highly recommended that you read and apply the advice in this Owners Manual before beginning installation.



TABLE OF CONTENTS

FEATURES	2
SPECIFICATIONS	3
CONTROLS & FUNCTIONS	4 ~ 10
PLANNING & MOUNTING YOUR SYSTEM	11
WIRING DIAGRAM	12 ~ 16
ADJUSTING & TUNING	17
TROUBLE SHOOTING & WARNING	18

FEATURES

GT2-400 • GT2-600 • GT2-900 • GT2-1300 • GT2-1800 GT4-900 • GT4-1200 • GT4-1800 • GT4-2600

- Regulated MOSFET PWM Power Supply
- Three-way Protection Circuitry
- High Level Input w/Signal Sense
- Pre-Amp Low Level Outputs (**GT2-400** , **GT2-600** , **GT2-900** , **GT2-1300** , **GT2-1800**)
- Low Level Input Sensitivity : 250mV ~ 6V
- Frequency Response : 10 ~ 35kHz
- Damping Factor : 250
- Total Harmonic Distortion : 0.05%
- Signal-to-Noise Ratio : 100dB
- Channel Separation : 65dB
- Variable 50~500Hz 12dB High Pass Crossover
- Variable 50~500Hz 12dB Low Pass Crossover
- Variable 0-12dB 45Hz Bass Boost
- 4 Gauge Power/Ground & 8 Gauge Speaker Terminals Connection
- Variable Low pass remote dash mounts gain control (**GT2-1300** , **GT2-1800**)

GT1-1000 • GT1-1600

- Regulated MOSFET PWM Power Supply
- Three-way Protection Circuitry
- Pre-Amp Low Level Outputs
- Frequency Response : 10 ~ 35kHz
- Total Harmonic Distortion : 0.05%
- Channel Separation : 65dB
- Variable 50~500Hz 12dB Low Pass Crossover
- Variable 20Hz~50Hz 12dB Subsonic Crossover
- 4 Gauge Power/Ground & 8 Gauge Speaker Terminals Connection
- Variable Low pass remote dash mounts gain control
- High Level Input w/Signal Sense
- Low Level Input Sensitivity : 250mV ~ 6V
- Damping Factor : 250
- Signal-to-Noise Ratio : 100dB
- 80Hz 12dB High Pass Crossover
- Variable 0-12dB 45Hz Bass Boost

GT5-2500

- Regulated MOSFET PWM Power Supply
- Three-way Protection Circuitry
- Frequency Response : 10 ~ 35kHz
- Total Harmonic Distortion : 0.05%
- Channel Separation : 65dB
- Variable 50~500Hz 12dB High Pass Crossover
- Variable 50~500Hz 12dB Low Pass Crossover
- 4 Gauge Power/Ground & 8 Gauge Speaker Terminals Connection
- Variable Low pass remote dash mounts gain control
- High Level Input w/Signal Sense
- Low Level Input Sensitivity : 250mV ~ 6V
- Damping Factor : 250
- Signal-to-Noise Ratio : 100dB
- Variable 0-12dB 45Hz Bass Boost

GT1-2400D • GT1-3500D • GT1-4500D • GT1-6000D

- Regulated MOSFET PWM Power Supply
- Three-way Protection Circuitry
- Pre-Amp Low Level Outputs
- Frequency Response : 10 ~ 35kHz
- Total Harmonic Distortion : 0.05%
- Channel Separation : 65dB
- Variable 40~150Hz 24dB Low Pass Crossover
- Variable 20~50Hz 24dB Subsonic Crossover
- 4 Gauge Power/Ground & 8 Gauge Speaker Terminals Connection
- Variable Low pass remote dash mounts gain control
- Data link system : Features allows the mono amps to be strapped or bridged via master / slave configuration
- Strippable for Double Power w/2-ohm
- Low Level Input Sensitivity : 250mV ~ 6V
- Damping Factor : 250
- Signal-to-Noise Ratio : 100dB
- 180° Phase Switch
- Variable 0-18dB 45Hz Bass Boost

SPECIFICATIONS

MODEL	CHANNEL	RMS@4Ohms	RMS@2Ohms	Bridged @4Ohms	Max Power	DIMENSIONS (W) x (H) x (L)
GT2-400	2	60W x 2CH	80W x 2CH	160W x 1CH	400Watt	9,75 x 2,375 x 7"
GT2-600	2	90W x 2CH	120W x 2CH	240W x 1CH	600Watt	9,75 x 2,375 x 7,75"
GT2-900	2	135W x 2CH	180W x 2CH	360W x 1CH	900Watt	9,75 x 2,375 x 9"
GT2-1300	2	200W x 2CH	260W x 2CH	520W x 1CH	1300Watt	9,75 x 2,375 x 11,75"
GT2-1800	2	280W x 2CH	360W x 2CH	720W x 1CH	1800Watt	9,75 x 2,375 x 13,75"
GT4-900	4	75W x 4CH	95W x 4CH	190W x 2CH	900Watt	9,75 x 2,375 x 9"
GT4-1200	4	100W x 4CH	125W x 4CH	250W x 2CH	1200Watt	9,75 x 2,375 x 11,5"
GT4-1800	4	150W x 4CH	190W x 4CH	380W x 2CH	1800Watt	9,75 x 2,375 x 13,75"
GT4-2600	4	215W x 4CH	275W x 4CH	550W x 2CH	2600Watt	9,75 x 2,375 x 15,75"
GT1-1000	1	375W x 1CH	470W x 1CH	—	1000Watt	9,75 x 2,375 x 9"
GT1-1600	1	600W x 1CH	750W x 1CH	—	1600Watt	9,75 x 2,375 x 11,5"
GT5-2500	5	100W x 4CH + 480W x 1CH	125W x 4CH + 600W x 1CH	250W x 2CH —	2500Watt	9,75 x 2,375 x 15,75"

MODEL	CHANNEL	RMS@4Ohms	RMS@2Ohms	RMS@1Ohms	Max Power	DIMENSIONS (W) x (H) x (L)
GT1-2400D	1	900W mono	1150W mono	1500W mono	2400Watt	9,75 x 2,375 x 10,75"
GT1-3500D	1	1300W mono	1650W mono	2100W mono	3500Watt	9,75 x 2,375 x 11,75"
GT1-4500D	1	1700W mono	2200W mono	2700W mono	4500Watt	9,75 x 2,375 x 14,75"
GT1-6000D	1	2300W mono	3000W mono	3700W mono	6000Watt	9,75 x 2,375 x 17,5"

CONTROLS & FUNCTIONS

FUSES

GT1-1000 • GT1-1600

GT1-1000 : 30A x 1
GT1-1600 : 25A x 2

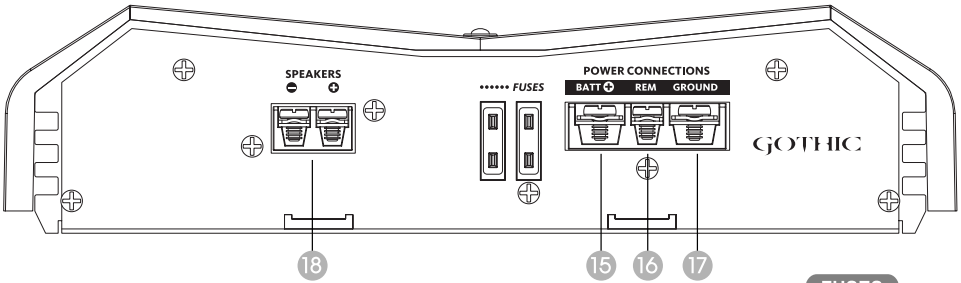
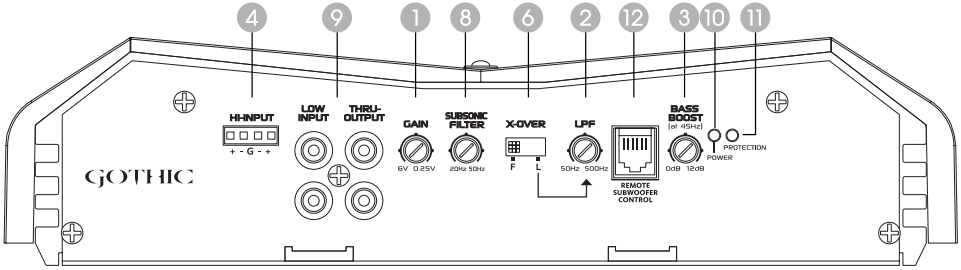

FUSES

GT2-400 • GT2-600 • GT2-900 • GT2-1300 • GT2-1800

GT2-400 : 15A x 1
GT2-600 : 20A x 1
GT2-900 : 30A x 1
GT2-1300 : 20A x 2
GT2-1800 : 25A x 2

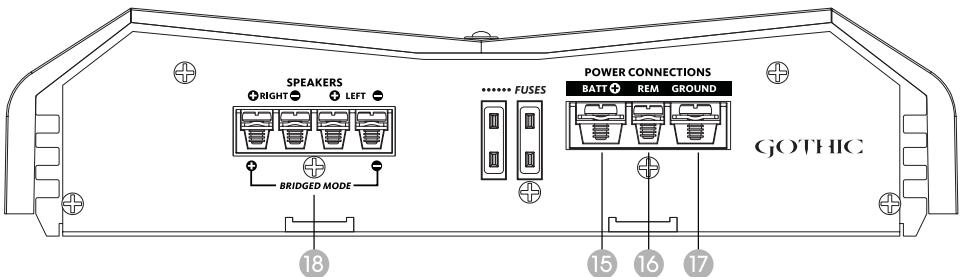
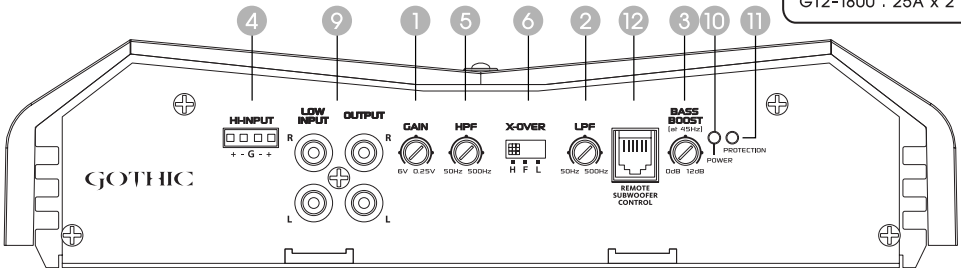

CONTROLS & FUNCTIONS

GT4-900 • GT4-1200 • GT4-1800 • GT4-2600

FUSES

- GT4-900 : 30A x 1
- GT4-1200 : 20A x 2
- GT4-1800 : 30A x 2
- GT4-2600 : 30A x 3

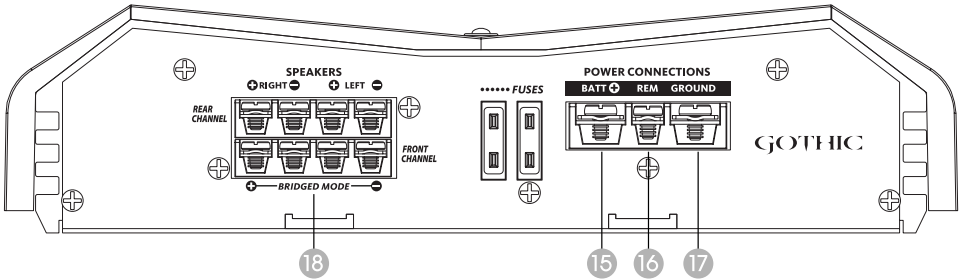
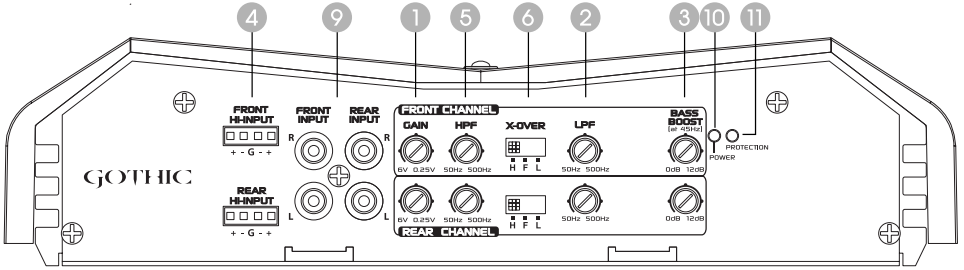

GT5-2500

FUSES

- GT5-2500 : 25A x 3

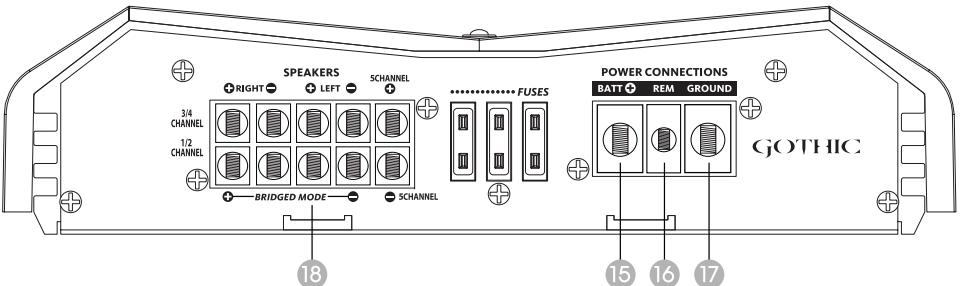
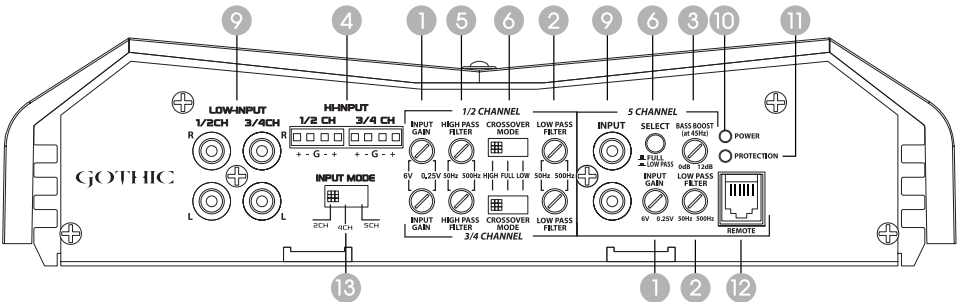

CONTROLS & FUNCTIONS

GT1-2400D • GT1-3500D • GT1-4500D • GT1-6000D

FUSES

- GT1-2400D : 30A x 2
- GT1-3500D : 30A x 3
- GT1-4500D : 30A x 4
- GT1-6000D : 30A x 5

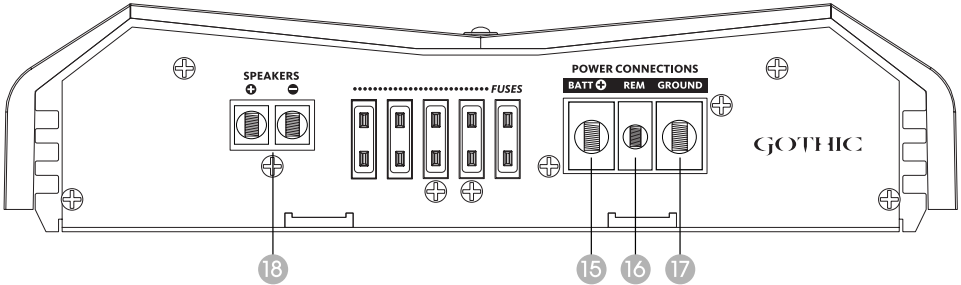
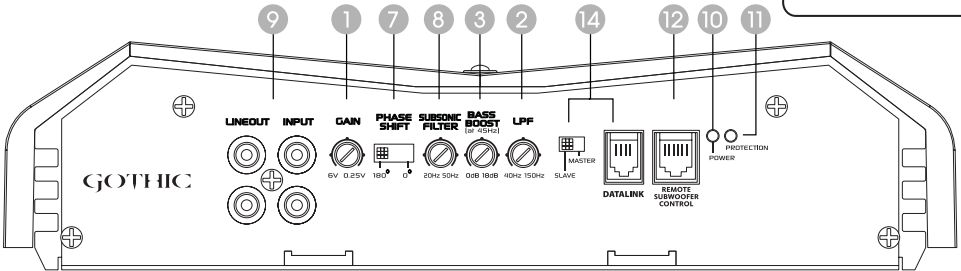

CONTROLS & FUNCTIONS

1. Input Level Adjustment

GAIN



6V 0.25V

This control adjusts the amplifier's input sensitivity. Input sensitivity is variable from 250 Millivolts to 6 volts. Clockwise increases sensitivity. Counterclockwise decreases sensitivity. The amplifier can be driven to full power with a wide range of signal levels. A lower signal level will require increased sensitivity for full power. A higher signal level will require decreased sensitivity. Avoid setting sensitivity lower than necessary as this would introduce unwanted distortion.

2. Low Pass Filter Control

LPF



50Hz 500Hz

LPF



40Hz 150Hz

GT1-2400D
GT1-3500D
GT1-4500D
GT1-6000D

Variable Low-Pass Filter :

Adjust variable crossover frequency with control as desired. The amplifier input circuit filters out everything above the frequency selected, so only the deepest bass notes are amplified.

3. Bass Boost Control

BASS BOOST
(at 45Hz)



0dB 12dB

BASS BOOST
(at 45Hz)



0dB 18dB

GT1-2400D
GT1-3500D
GT1-4500D
GT1-6000D

The 'BASS BOOST' function can be selected to increase low frequency response output, or decrease frequency response output.

4. Hi-Input Connector

HIINPUT



+ - G - +

Do not connect at low input and high input and on same time
Because the sound is very bad.

If your installation by using a high level, you do not need to connect to the remote wire, because a high-level input by detecting the audio signal amplifier is turned on.

To hear a better sound quality, you must be a high level of the ground shall be connected to your Head-unit Ground.

5. High Pass Filter Control

HPF



50Hz 500Hz

Variable High Pass Filter (50Hz - 500Hz)

For use as a dedicated mid high range channel, set Filter Switch to "HIGH PASS".

The Input Circuit filters out all Frequencies Below 50Hz ... 500Hz.

6. Crossover Mode Switch

CROSSOVER MODE



HIGH FULL LOW

X-OVER



F L

GT1-1000
GT1-1600

SELECT



FULL LOWPASS

GT5-2500 5Channel Push switch

Adjust the crossover for your chosen installation method.

LOW PASS : Low pass filter - only bass tones(50Hz-500Hz)go to speakers. Use with woofer or subwoofer. **FULL RANGE** : No filter - all tones go to speakers. Use with full-range speakers, or with external crossovers. **HIGH PASS** : High pass filter - blocks very low tones(50Hz-500Hz) from the speakers.

CONTROLS & FUNCTIONS

7. Phase Shift Control



Phase Shift Switch (0 and 180 degrees) :

Allows you to change the phase of your subwoofer from 0 to 180 degrees to help compensate for timing differences between drivers.

8. Subsonic Filter Control



Variable Subsonic Filter (20Hz - 50Hz)

The Subsonic Filter will roll off all of the unwanted frequencies below 20Hz - 50Hz. This will allow the amplifier to use that wasted power on the audible bandwidth.

9. Low Level Input & OUT RCA Jacks

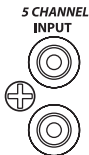
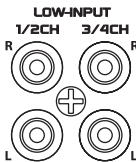

GT5-2500

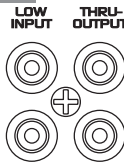

GT1-1000
GT1-1600

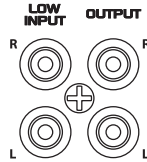

2 CH

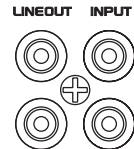

CLASS D MONO CH

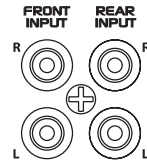

4 CH

These inputs are for signal cables from the source. Always use high quality shielded RCA cables. The LINE OUT allows you to build multiple amplifier systems without having to use splitter cords to distribute the signal. Now it is simply a matter of bringing one set of RCAs into the first amplifier, then using the line out RCA jacks as the feed to the next amplifier.

10. Power LED Indicator



Power : This Green LED will illuminate when the amplifier is turned "ON".

If it fails to illuminate, check the power connections to the amplifier and fuses.

11. Protection LED Indicator



Protection : The amplifier protection circuitry will disable the amplifier ; if input overload, short circuit or extremely high temperature conditions are detected. When the protection mode is in operation, the LED indicator on the side panel will be illuminated, indicating the amplifier has gone into a self-preservation mode.

If you observe that the Protection LED is lit, please check the system carefully to determine what has caused the protection circuit to engage. The amplifier can be reset by turning the remote power off and then on again. If the amplifier shuts down due to a thermal overload condition, please allow it to cool down before restarting. If the amplifier shuts down because of an input overload or short circuit, be sure to repair these conditions before attempting to power up the amplifier again.

CONTROLS & FUNCTIONS

12. Remote Control Input



Remote Bass Boost Control : This control adjusts the Bass Boost gain for the amplifier's speaker output (0 ~ +18dB)

* Packed product can be different from the photograph.

13. Input Mode Select Switch

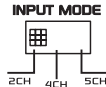

Please see Page 8!

14. Bridged Mode Switch

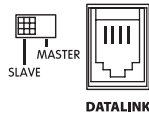

*Master Mode

For bridging into a single speaker load , to do this you must utilize the MASTER / SLAVE switch settings. For the MASTER amplifier , set the switch setting to MASTER. This will route the signal through RCA to the other (slave) amplifier. On the slave amplifier set this switch to the SLAVE position. Refer to Auxiliary Output Configuration section of this guide.

Set the PHASE switch on the slave amp, move the phase switch from 0 to 180 , exactly opposite of the master amp. Refer to the Phase switches section of this guide.

*Slave Mode

On the slave amplifier be sure to turn off all crossovers. For the speaker connections , connect the positive (+) speaker lead from the speaker to the positive (+) speaker terminal of the master amplifier. On the negative (-) speaker connection , take the negative (-) speaker terminal of the master amplifier and connect it directly to the negative (-) speaker terminal of the slave amplifier.

The remaining positive (+) speaker terminal of the slave amplifier must be connected to the negative (-) speaker lead from the speaker.

The impedance of the speaker must not exceed 2Ω .

NOTE : For best results , connect both negative speaker terminals on the master amp to both negative terminals on the slave amp using at least 12 AWG cables.

CONTROLS & FUNCTIONS

15. B+ Terminal (Battery positive)

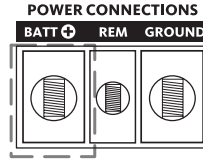
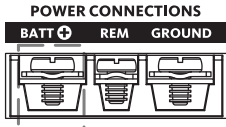

Due to the power requirements of the Amplifier, this connection should be made directly to the positive(+) terminal of battery. For safety measure, install an in-line fuse holder (not included) as close to the battery positive(+) terminal as possible with an ampere rating : not to exceed total value of fuses on AMP.

16. Remote Power ON

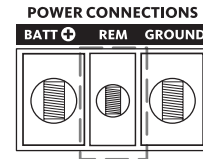
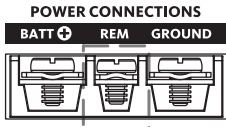

In between the power and ground is remote turn on terminal. This terminal must be connected to a switched +12Voltage source. You need to use at least 18gauge to connect remote turn on.

17. B-Terminal (Chassis ground)

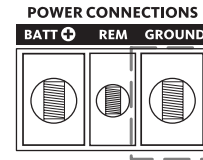
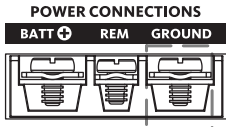

To avoid unwanted ignition noise caused by ground loops, it is essential that the Amplifier be grounded to a clean, bare, metal surface of the vehicles chassis.

Note : GROUND WIRE SHOULD NOT BE EXTENDED MORE THAN 3FT (1METER) IN SOME CASES !

18. Speaker Terminals

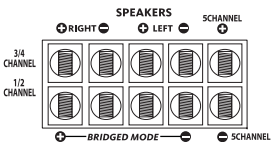

GT5-2500

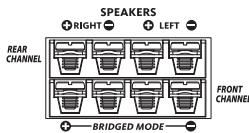

4 CH

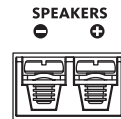

GT1-1000
GT1-1600

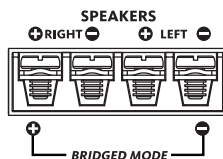

2 CH

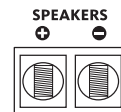

CLASS D MONO CH

You need to use at least 12 gauge to connect speaker.

PLANNING & MOUNTING YOUR SYSTEM

The mounting position of your Amplifier will have a great effect on its ability to dissipate the heat generated during normal operation.

Under normal conditions, the heatsink will dissipate sufficient heat to avoid thermal shutdown. However please do not install the amplifier in a wooden box or similar device, as this will prevent heat dissipation into the atmosphere.

Temperatures in car trunks have been measured as high as (155°F) in the summer time. Since the thermal shut-down point for the amplifier is (158°F) it is easy to see that it must be mounted for maximum cooling capability. To achieve maximum advantage of convection air flow in an enclosed trunk, mount the amplifier in a horizontal position.

Cooling requirements are considerably relaxed when mounting inside the passenger compartment since the driver will not often allow temperatures to reach a critical point. Floor mounting under the seat is usually satisfactory as long as there is at least 1 inch of clearance (2.54cm) above the Amplifier's fins for ventilation.

- A. Select a suitable location that is convenient for mounting, is accessible for wiring, and has ample room for air circulation and cooling.
- B. Use the amplifier as a template to mark the mounting holes. Remove the Amplifier and drill holes. Use extreme caution, inspect underneath surface before drilling!
- C. Secure the Amplifier using the screws provided.

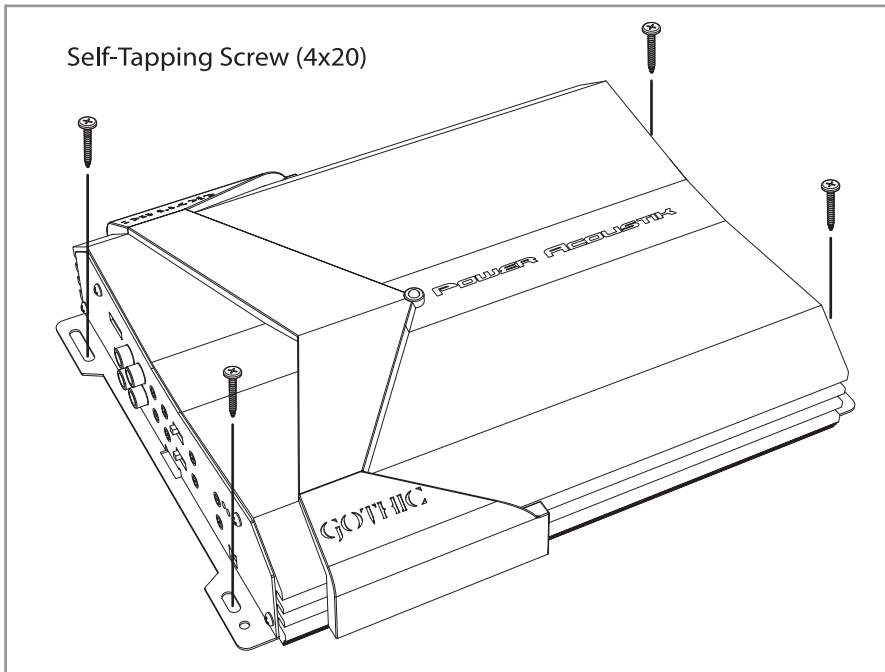

WIRING DIAGRAM

GT1-1000 • GT1-1600

Mono mode

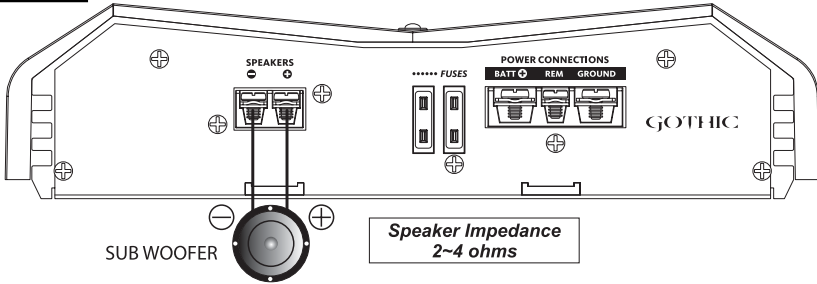

GT2-400 • GT2-600 • GT2-900 • GT2-1300 • GT2-1800

Mono mode

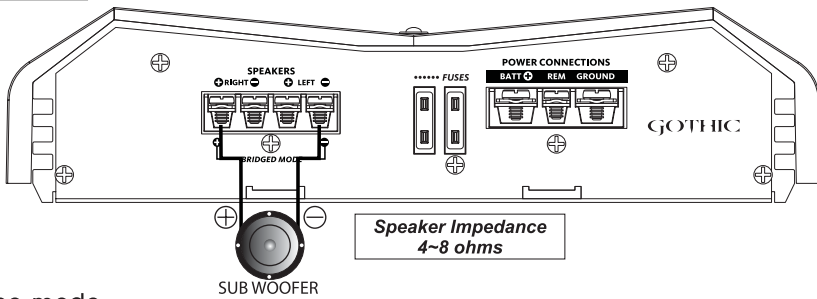

Stereo mode

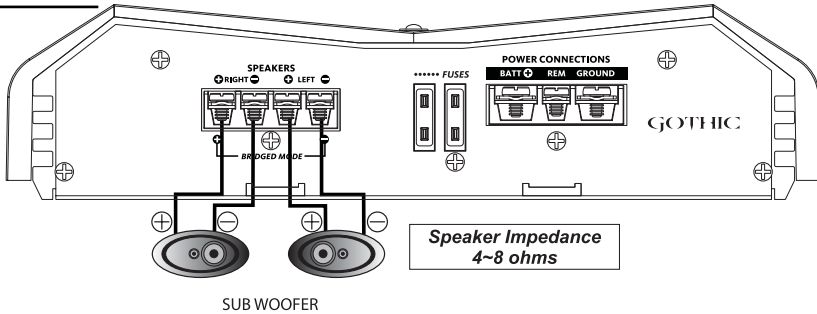

Tri mode

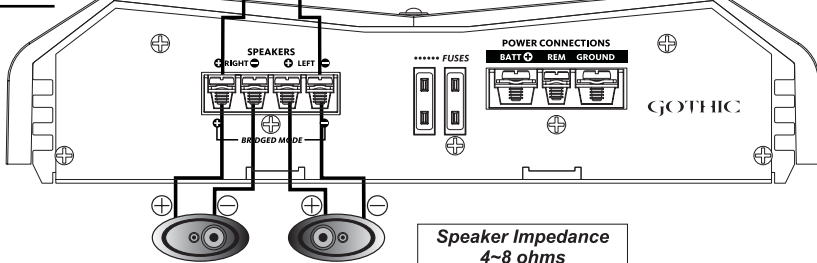

WIRING DIAGRAM

GT4-900 • GT4-1200 • GT4-1800 • GT4-2600

2Channel mode

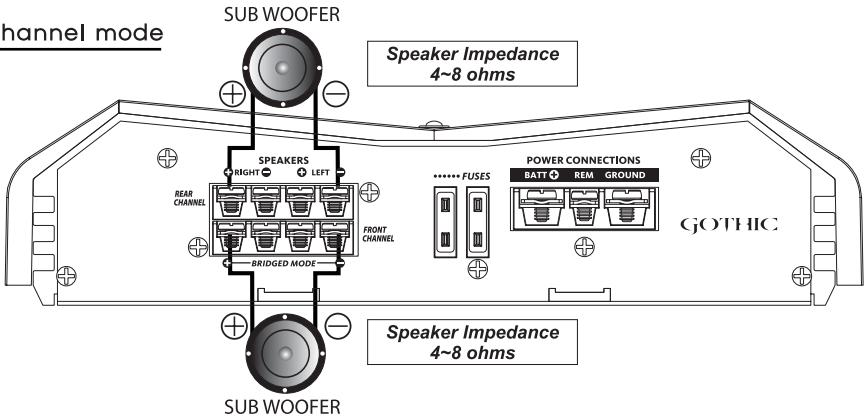

Tri mode

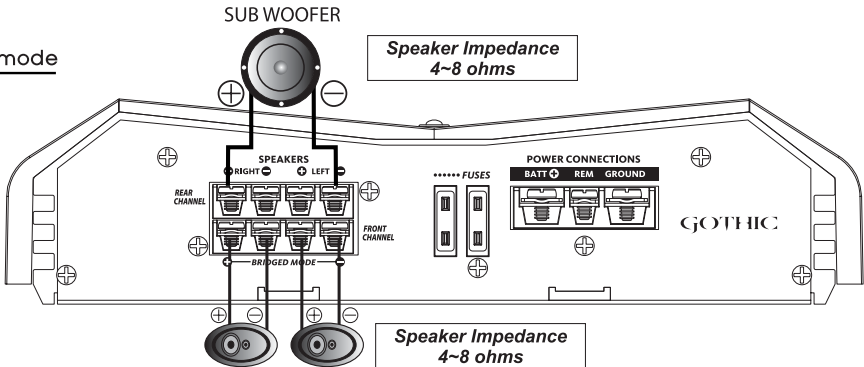

Stereo mode

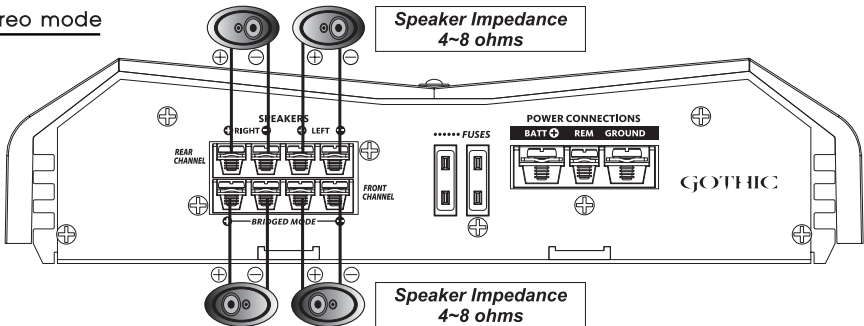

WIRING DIAGRAM

GT5-2500

INPUT 2Channel mode

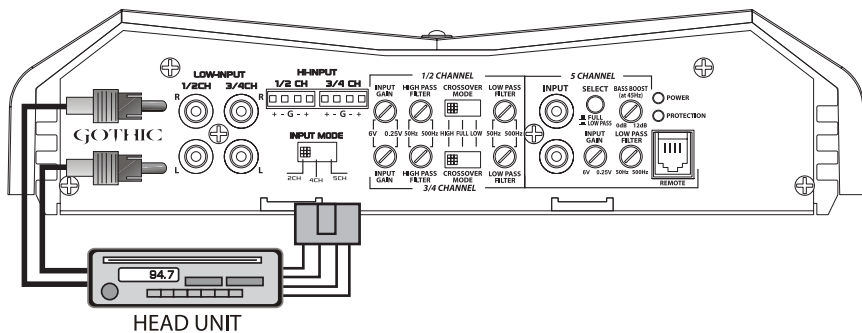

★ CAUTION : INPUT MODE SELECT SWITCH POSITION

INPUT 4Channel mode

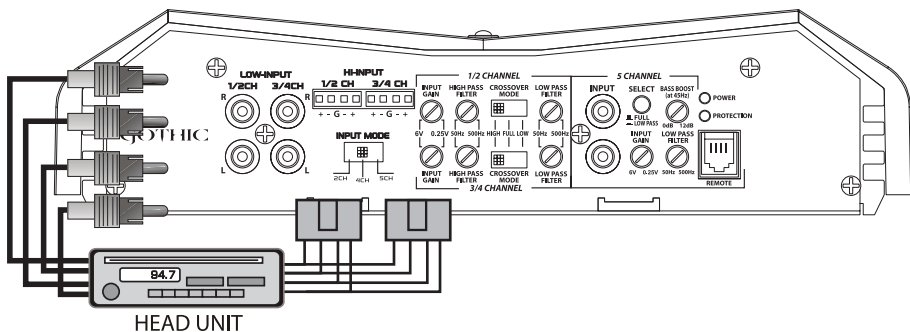

★ CAUTION : INPUT MODE SELECT SWITCH POSITION

INPUT 5Channel mode

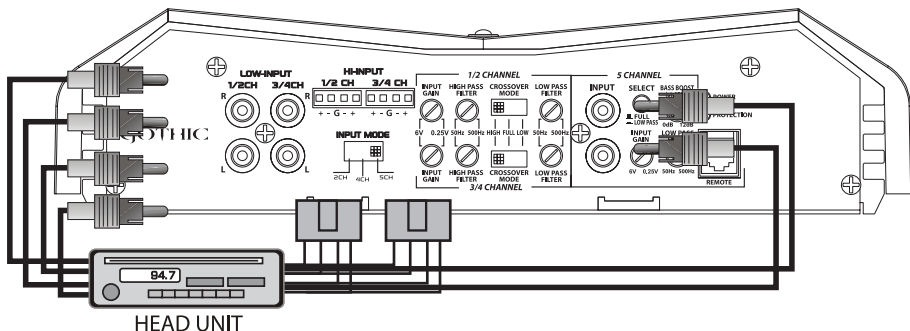

CAUTION : INPUT MODE SELECT SWITCH POSITION

WIRING DIAGRAM

GT5-2500

3Channel mode

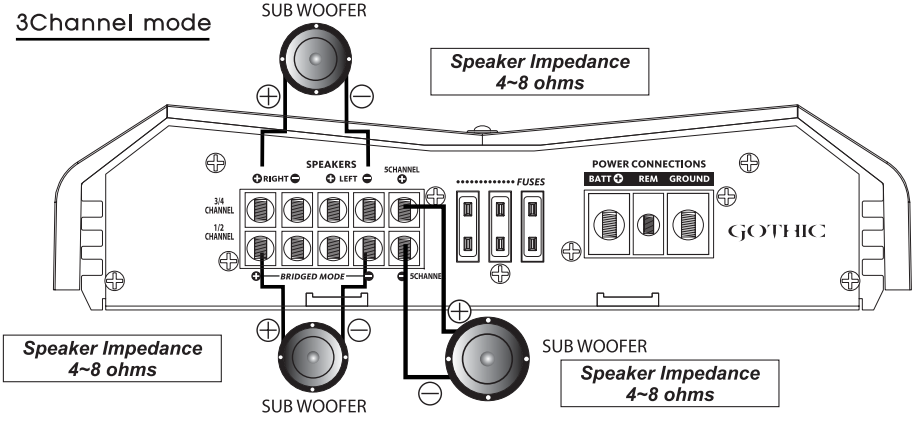

4Channel mode

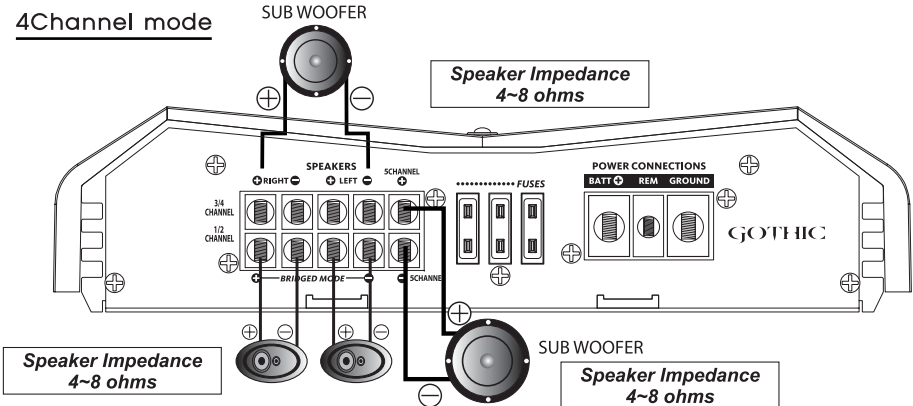

5Channel mode

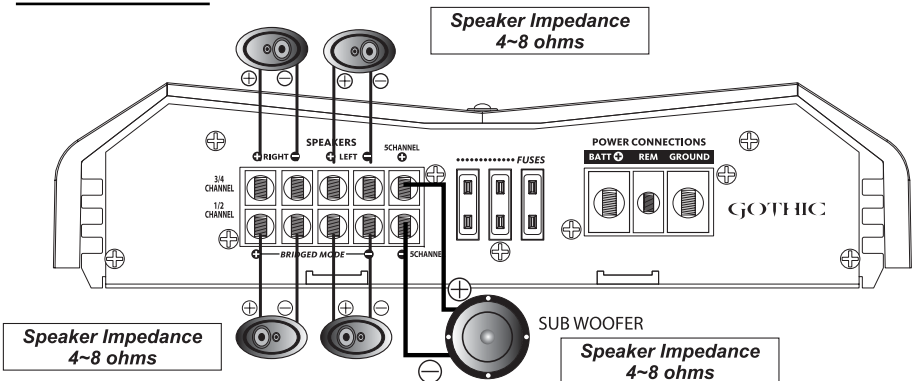

WIRING DIAGRAM

GT1-2400D • GT1-3500D • GT1-4500D • GT1-6000D

Mono mode

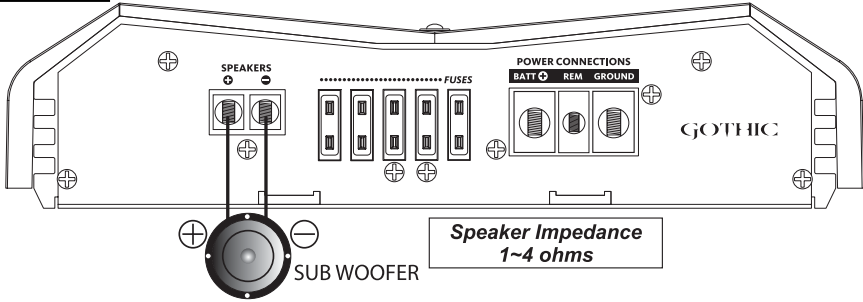

Bridging two Amplifiers

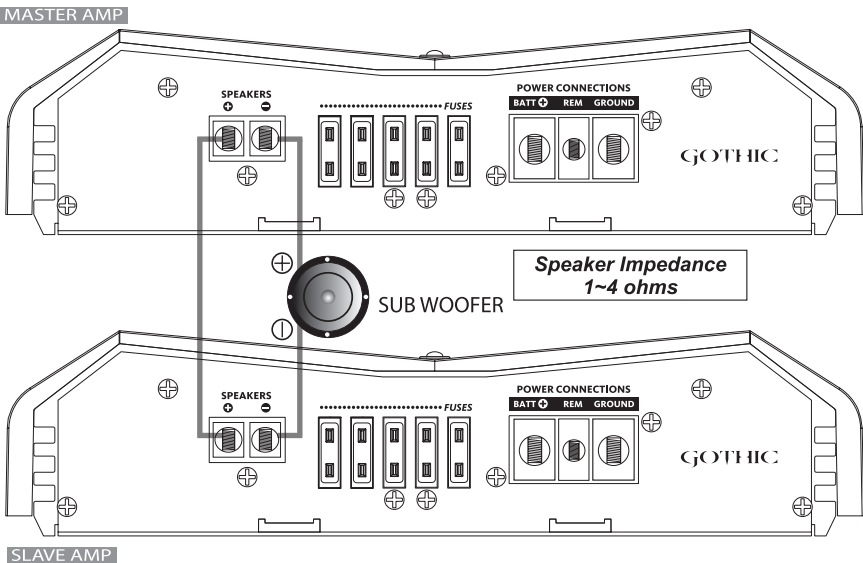
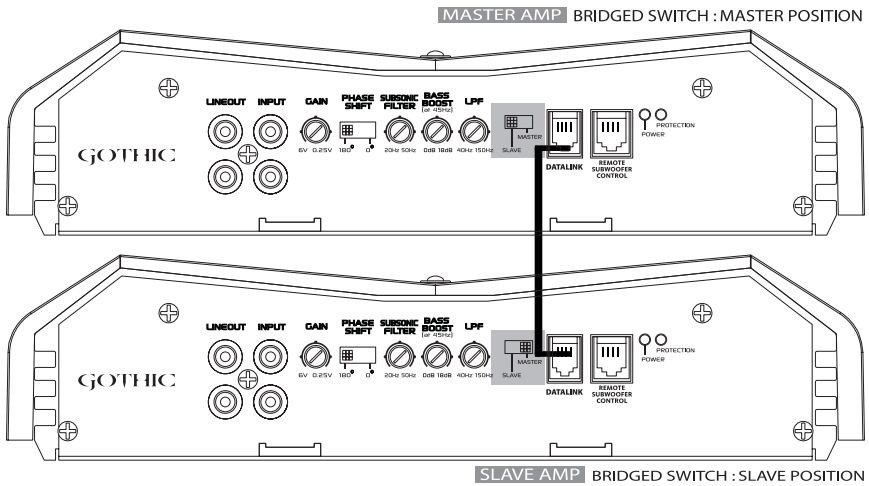

TURNING ON THE AMPLIFIER

The amplifier automatically turns on a few seconds after you turn your vehicle's ignition switch to ACC or ON or turn on your auto sound system, depending on how you wired the system. The POWER Indicator on the top of the amplifier lights when the amplifier is on.

Important : Your amplifier requires 30 amps or more of power from your vehicle's battery during operation. To protect your battery from discharging, do not operate the amplifier unless your vehicle is running.

ADJUSTING THE AUDIO LEVEL

For the best performance, you must set GAIN(MIN/MAX) on the side of the amplifier to adjust the level of the audio signals that enter the amplifier.

1. Use a screwdriver to turn GAIN(MIN/MAX) fully counterclockwise to MIN.
2. Turn the auto sound system's volume control to about one-third of its full range.
3. Adjust GAIN(MIN/MAX) to a comfortable listening level.
4. Turn up the auto sound system's volume control until the sound begins to distort. Then immediately turn the volume down to a point just before where the distortion began.

Caution : Never turn up the auto sound system's volume control more than needed to adjust the audio level, more than two thirds of its maximum volume.

5. Adjust GAIN(MIN/MAX) until the sound is at the maximum level you want the amplifier to produce.
6. Adjust the auto sound system's volume control to a comfortable listening level.

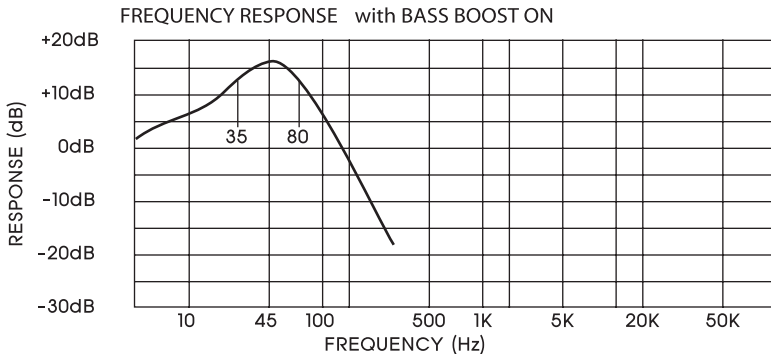

NOTE : Raising the Bass Frequency allows higher frequencies to reach the bass speakers centered around 45Hz. This "BUMP" can have a dramatic effect on the bass system's apparent volume. Use caution! When adjusting this control as serious subwoofer damage may result from overpowering or overexcursion.

TROUBLE SHOOTING

SYMPTOMS	CHECK	REMEDY
NO SOUND	Is the power LED illuminated? (NO)	Check all fuses to amplifier. Be sure Turn-on lead is connected Check signal leads. Check gain control. Check Tuner/Deck volume level. Clean contacts on fuse holders.
	Is the Diagnostic LED illuminated? (YES)	Check for speaker short or amplifier overheating.
AMP NOT SWITCHING ON	No power to power wire	Repair power wire or connections.
	No power to remote wire with receiver on	Check connections to radio.
	Burnt or broken fuse	Replace fuse
NO SOUND, ON ONE CHANNEL	Check Speaker Leads	Inspect for short circuit or an open connection.
	Check Audio Leads	Reverse Left and Right RCA inputs to determine if the problem is occurring before the amp.
AMP TURNING OFF MEDIUM/ HIGH VOLUME	Check Speaker load impedance	Be sure proper speaker load impedance recommendations are observed. (If you use an ohmmeter to check speaker resistance, please remember that DC resistance and AC impedance may not be the same.)
PROTECTION LAMP ON	Shut down	Turn radio down Wait for AMP to cool
	Speaker wires shorted	Separate speaker wires and insulate

WARNING

Investigate the layout of your automobile through before drilling or cutting any holes. Take care when you work near the gas tanks, lines, or hydraulic lines, and electrical wiring. Don't use power amplifier without securely mounting it. Attach this system securely to the automobile to prevent damage, particularly in the event of an accident. Don't mount this system so that the wire connections are unprotected or are subject to pinching or damage from nearby objects. The +12V DC power wire must be fused at the battery positive terminal connection. Before making or breaking power connections at this system power terminals, disconnect the +12V wire at the battery end. Confirm your radio/cassette player and/or other equip is turned off while connecting the input jacks and speaker terminals. If you need to replace the power fuse, replace it only with a fuse identical to that supplied with the system. Using a fuse of different type or rating may result in damage to this system which isn't covered by the warranty.



POWER ACOUSTIK®

Please Keep This Information For Your Records

Model Number: _____

Serial Number: _____

Date Purchased: _____

Dealer Name: _____

Dealer Address: _____

City: _____ State: _____ Zip: _____



STAMP

Power Acoustik
1550 S. Maple Ave.
Montebello, CA 90640
Attn. Customer Service

CONSUMER LIMITED WARRANTY

PowerAcoustik Electronics. (The Company) warrants to the original retail purchaser of its products that should this product under normal use and conditions, be proven defective in material or workmanship within **1 Year from the original date of purchase and professional installation or 90 Days if self installed.** Those items with manufacturer's defects will be repaired or replaced at our option with or without charge for parts and repair labor.

To obtain repair or replacement within the terms of this warranty, the product or products are to be returned with proof of warranty coverage (e.g. a copy of the receipt for your purchase and installation). Specific information of the nature of the defect(s), **all transportation costs are to be paid by the sender including a cashier's check for \$15.00 to cover the return freight and packing.**

This warranty does not extend to the elimination of externally generated static or noise, or to cover installation costs for initial installation, removal or reinstallation of the products or to damaged, media sources (DVDs, VHS tapes, Speakers, Amplifiers, Car stereos or Electrical System Failures).

This warranty does not apply to any product or part thereof which, in the opinion of the company, has been abused or damaged through alteration or modification, improper installation, mishandling, misuse, neglect, accident, or by the removal of the unit. **The Extent of the company's liability under this warranty is limited to the repair or replacement provided above and, in no event, should the company's liability exceed the purchase price paid by the purchaser for the product.**

This warranty is in lieu of all other express warranties or liabilities. **Any implied warranties, including any implied warranty of merchantability, shall be limited to the duration of this written warranty. Any action for breach of warranty hereunder including any implied warranty of merchantability must be brought within a period of 48 months from the original date of purchase. In no case shall the company be liable for any consequential or incidental damages for breach of this or any other warranty, express or implied, whatsoever.** No person or representative is authorized to assume for the company any liability other than expressed herein in connection with the sale of this product.

Some states do not allow limitations on how long an implied warranty lasts or the exclusion of incidental or consequential damage so the above limitations or exclusions may not apply to you. This warranty gives you specific legal rights and you may also have other rights, which vary from state to state.

PowerAcoustik Electronics,
1550 S. Maple Ave. Montebello, CA. 90640
Phone # 1-800-832-4647

Owners Registration Card.

Please complete and return immediately to the address on the reverse side

Name: _____

Address: _____

City: _____ State: _____ Zip: _____

Vehicle Make/Model: _____

Product Model: _____

Serial Number: _____

Date Purchased: _____

Name of Dealer: _____

Dealer Address: _____

City: _____ State: _____ Zip: _____

Phone: _____ Website: _____

