

TROUBLE SHOOTING GUIDE

If the unit does not turn-on, and / or the power indicator LED is NOT illuminated, do this:

- 1) Check and make sure that B+ and GND are not reversed.
- 2) Check that all power wires are properly connected and have 12 - 15 volts.
- 3) Check that the fuse is intact.

If you experience high audible distortion or low output volume:

- 1) Check that the input and output levels are set correctly. Input should match the source and output should match the sensitivity of the host.
- 2) Check the crossover settings; make sure they are correct.

If you experience whining or engine noises:

- 1) Verify that the GND connection is secure and the wire is not too thin and unnecessarily long.
- 2) Check that the B+ wire is not too thin and unnecessarily long.
- 3) Change the power source; try taking power from a different point.

INSTALLATION

TAPPING SCREW

SPRING WASHER

PLAIN WASHER

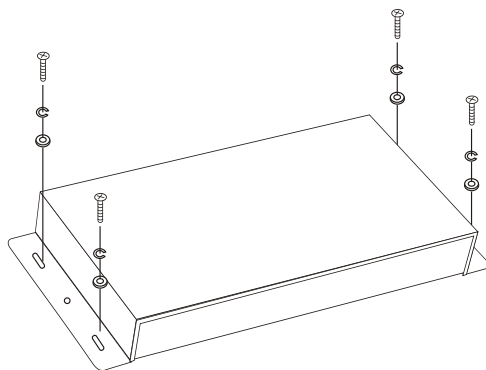

- end -

SOUNDSTREAM®
T E C H N O L O G I E S

XBP-10

SPL TUNING MACHINE

Owner's Manual
and
Installation Guide

Congratulations!

Congratulations on purchasing the **SOUNDSTREAM** XBP-10. You are now the proud owner of the finest and most accurate bass processor system available.

To maximize the performance of your system, we recommend that you thoroughly acquaint yourself with its capabilities and features. Please retain this manual and your sales receipt for future reference.

Serial # _____

Dealer's Name _____

Date of Purchase _____

Installation Shop _____

Installation Date _____

CAUTION!

Prolonged listening at extremely high levels may result in hearing loss. Please exercise caution to prevent hearing damage.

Features

- SPL Competition Signal Processor
- 2 Signal Paths – Sound Quality & Sound Pressure Level
- Individual Level Control for each Signal Path
- 5Volt or 10Volt Signal Voltage Switch
- 50Hz Tone Generator for Tuning
- Variable 25-85Hz Bass EQ
- Dash Remote with Boost Level, Subsonic Filter, and SQ-to-SPL Signal Path Switch
- 4 Pairs of Outputs – 1 Main and 3 w/ Variable Delay for Time Alignment of Subwoofers
- Through Pass Outputs
- Turn On/Off Delay to Eliminate Pops
- Hi level inputs for oem intergration
- 5V or 10V at clipping switch

SPECIFICATIONS

Maximum Input Level	15 V rms
Maximum Output Level	13.5V peak
Frequency Response.....	10Hz - 100KHz ; +/-1dB
Total Harmonic Distortion.....	0.003%
Signal to Noise Ratio.....	130dB
Balanced Input Noise Rejection.....	>60dB
Input Impedance.....	10 Kohm
Output Impedance.....	150 Ohms
Power Supply.....	High headroom PWM
Power draw.....	150mA
Recommend fuse rating	1 Amp

Functions And Operations:

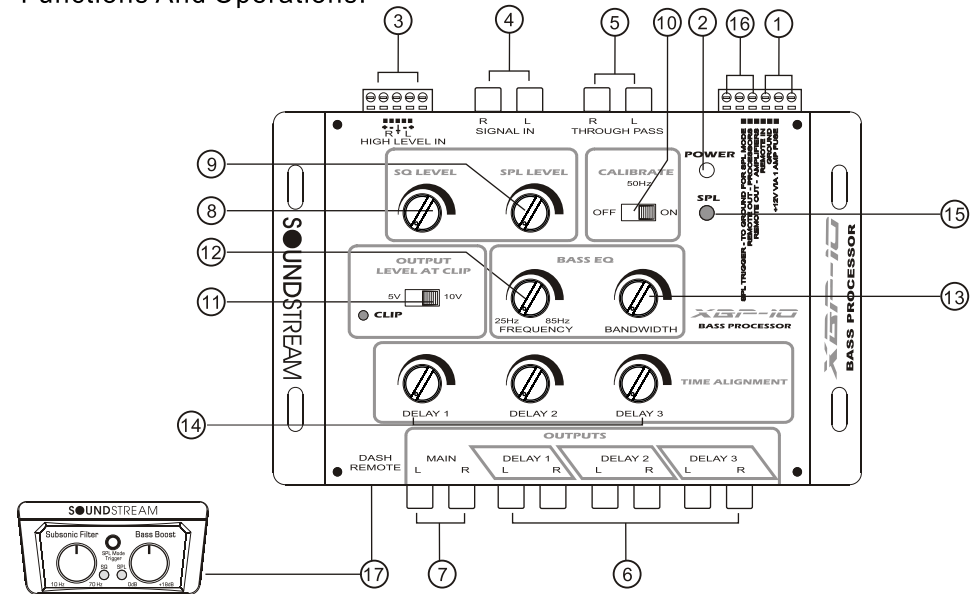

1. Power Connector
2. Power On LED Indicator
3. High Level Input
4. Low Level (RCA) Input
5. Full Range (RCA) Signal Output
6. RCA Output Terminal of Delay 1, Delay 2, & Delay 3
7. RCA Output Terminal
8. SQ Level Control
9. SPL Level Control
10. Calibrate 50Hz On/Off Switch
11. Output Level At Clip Selector
12. Bass EQ Frequency Control 25Hz 85Hz
13. Bass EQ Bandwidth Control
14. Time Alignment Control: Delay 1, Delay 2, & Delay 3
15. SPL ON indicator
16. A:- SPL Trigger - To Ground For SPL mode
B:- Remote out - Processors
C:- Remote out - Amplifiers
17. Remote control

ELECTRONIC CONNECTIONS & WIRING

Power connection

- **B+(12V)** : Connect a red wire to the car battery or other power source.
- **REMOTE** : Connect a blue wire to remote (12V DC) wire of car stereo.
- **GND** : Connect a black wire to the car chassis for ground connection.

TIME DELAY

Each output can be delayed individually. The goal is to get all subwoofers to hit the mic at the same time. The farthest sub away from the mic will not require any delay and will go to the MAIN output. The next farthest sub will require the least amount of delay and will go in DELAY 1, and so forth.

Set all delays to minimum. Make sure the Bass EQ section controls are also turned all the way counter clockwise. With a test tone, start with DELAY 1 and slowly adjust the time alignment until you find the sweet spot and see the most gain. Proceed to DELAY 2 and then 3 and 4.

For systems with more than 4 subs, you can link more than one XBP-10 together.

Vehicles with subs that are far away from the mic on the back will not see as much of a gain as when the subs are a lot closer. Vehicles with walls of woofers will see the most gain due to the larger variance in distance from cone to mic.

This is the Master Basster!!!

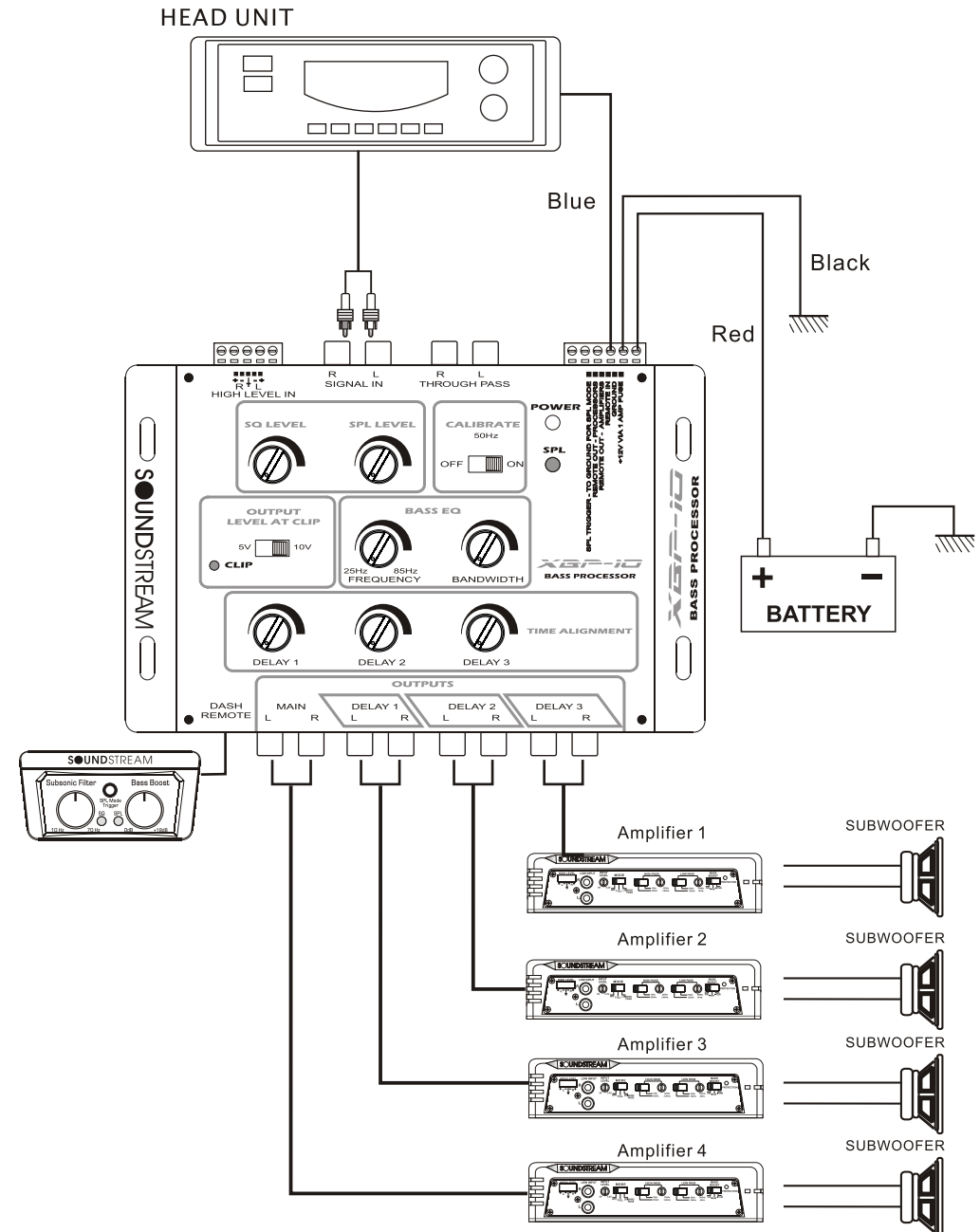

SIGNAL PATHS

SQ in SQ mode, the bass processing is bypassed and sounds better when listening to music. You can keep this gain lower so that it is properly level matched.

SPL in SPL mode, everything is active. Once the processing is set, a simple push of a button takes you from sound quality to competition via the button on the dash mounted remote.

CALIBRATION TOOL

When switched on, the calibration tool sends a 50Hz test tone to all outputs. This comes in handy when setting the delay controls accurately.

OUTPUT LEVEL AT CLIP

Some amplifiers handle more signal voltage than others. This feature allows you to set the clip level for the line driver in two stages to accommodate all amplifiers.

BASS EQ

The Bass EQ works as a parametric 1-band sub frequency equalizer. You can pin point the exact frequency you need with the infinitely variable control. The Bandwidth control allows you to choose the Q or bandwidth of the boost. Choosing the minimal setting boosts a very narrow band and strongly highlights the desired frequency. Choosing the maximum setting boosts a much wider bandwidth and smoothes out the neighboring frequencies.

See drawing below

